

MHF[®] 4

低背设计，组合高度最大1.2 mm，最适用于空间有限的设计

Product Specifications:

Mated Height	1.2 mm max.	
Rece. SMT Size	2.0 x 2.0 mm	
Applicable Frequency	DC ~ 9 GHz	
Characteristic Impedance	50 ohm	
VSWR (L = 100 mm)	DC ~ 3 GHz	1.3 max.
	3 ~ 6 GHz	1.5 max.
	6 ~ 9 GHz	2.0 max.

Applicable Cable Size:

O.D. 0.81 mm/AWG 36

Applicable Standards (Reference Only):

5G sub-6, Wi-Fi 6, LTE/LTE-Advanced, LPWA, Bluetooth, GPS



▶ 对应 9 GHz 的高性能小型连接器

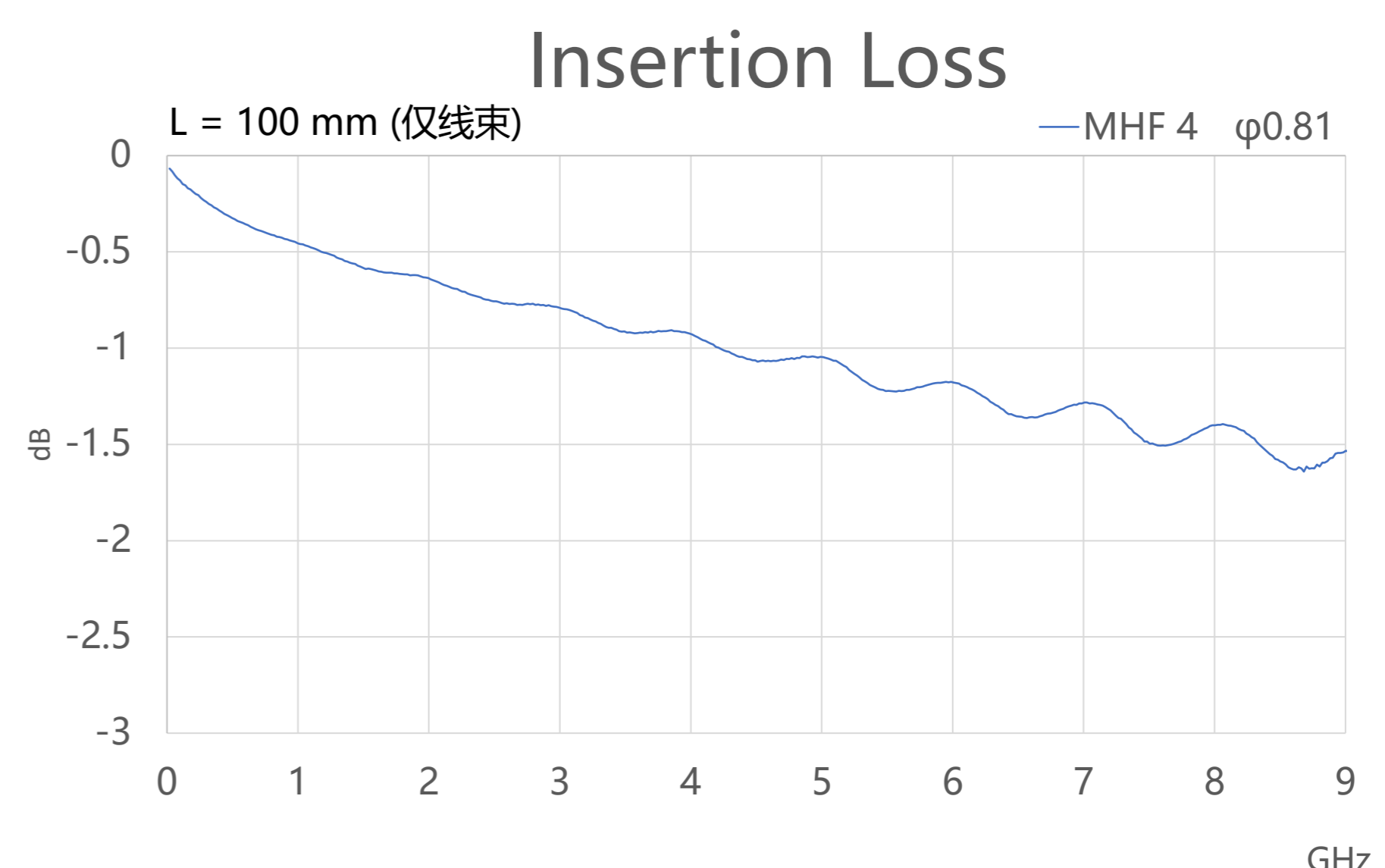
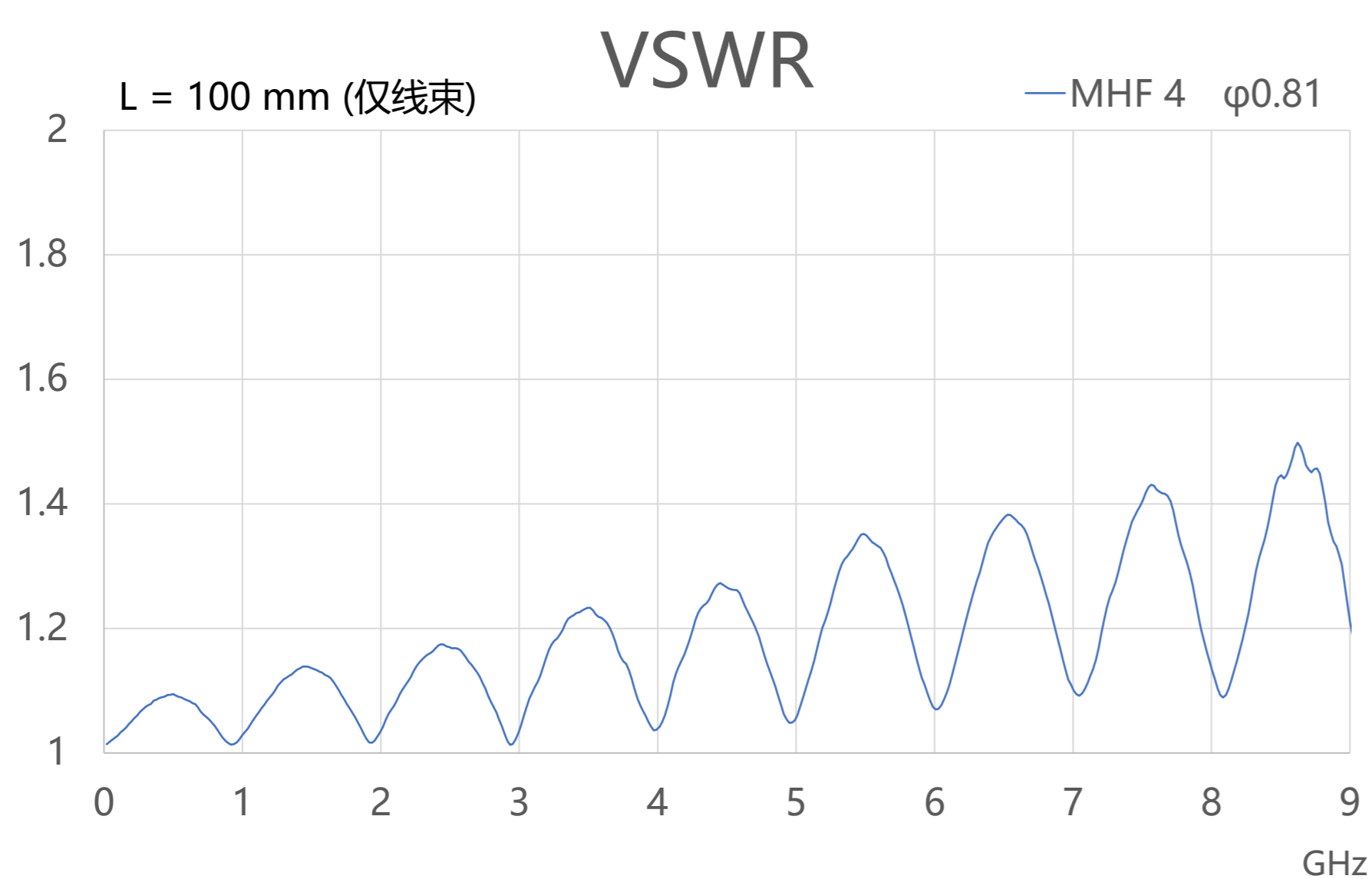

▶ 使用“i-Fit[®]”技术的无需焊接极细同轴线连结

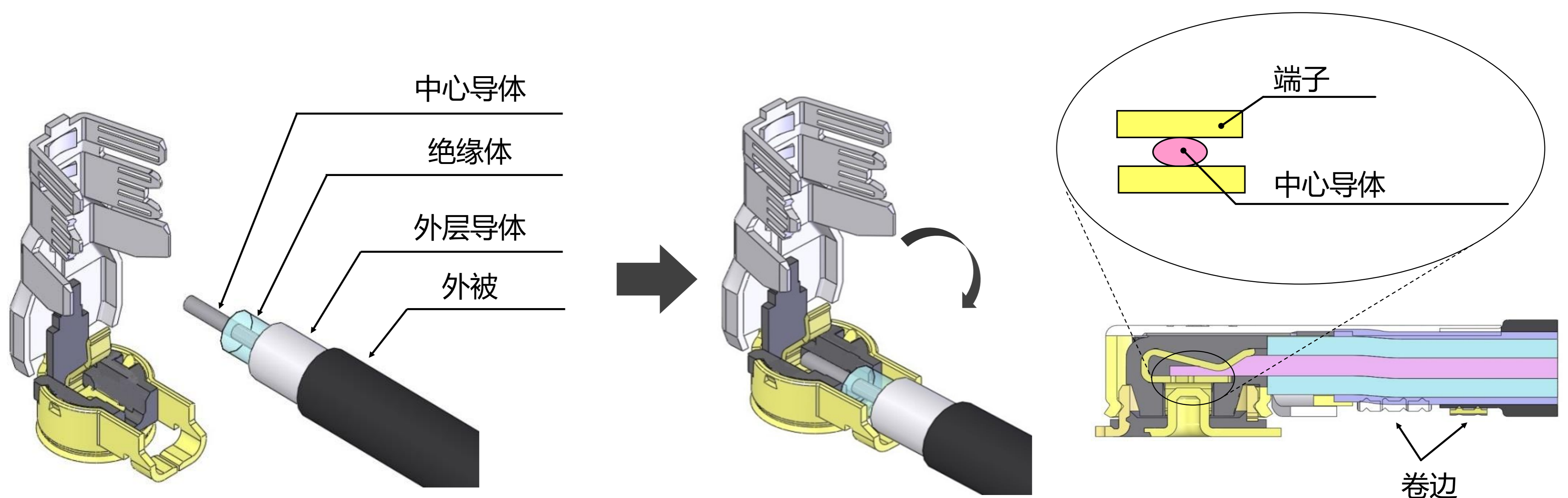

▶ MHF[®] 4 公座适用的极细同轴线外径 (AWG): 0.81 mm (36)

Product name	MHF [®] 4L			MHF [®] 4
Frequency	DC ~ 12 GHz (MHF [®] 4L Plug x MHF [®] 4L Rece.) DC ~ 9 GHz (MHF [®] 4L Plug x MHF [®] 4 Rece.)			DC ~ 9 GHz
Mating Height	1.7 mm max.	1.4 mm max.	1.2 mm max.	1.2 mm max.
Coaxial O.D. (Center Conductor AWG)	1.37 mm (AWG 30)	●		
	1.13 mm (AWG 32)		●	
	0.95 mm (AWG 33)		●	
	0.81 mm (AWG 36)			●
	0.64 mm (AWG 36)			●
Receptacle	MHF [®] 4L/MHF [®] 4 receptacle			MHF [®] 4L/MHF [®] 4 receptacle

MHF® 4 standard harness

- ◆ Please click the part number to get its 2D drawing.
- ◆ Please be advised that if it becomes necessary to change the harness specifications, the part number will also need to be updated. The following part number is valid only when used with the harness specifications shown below.
- ◆ Please contact us via [Inquiry form](#) for other harness specifications.

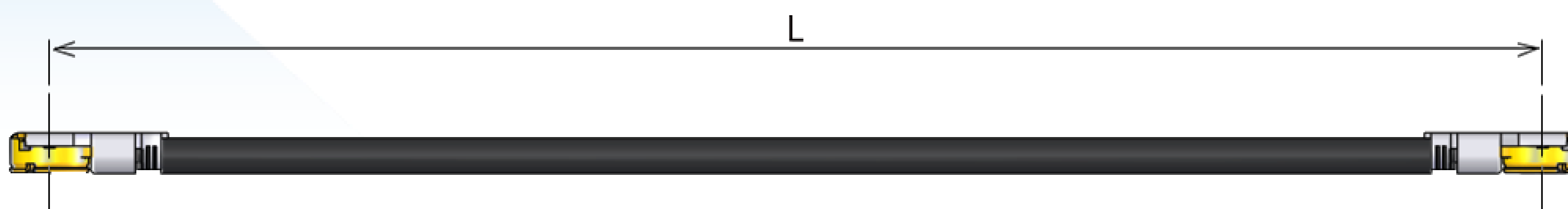

Part Number Description	Part Number (Link to Drawing)	Sample available
MHF 4-4 harness OD=0.81mm L=100mm	8-25-0886	Contact us
MHF 4-4 harness OD=0.81mm L=200mm	8-25-0887	Contact us
MHF 4-4 harness OD=0.81mm L=500mm	8-25-0890	Contact us

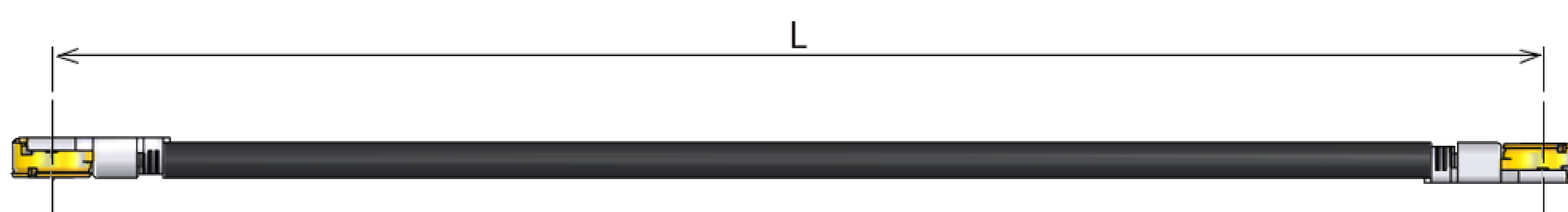

Part Number Description	Part Number (Link to Drawing)	Sample available
MHF 4-4 harness OD=0.81mm L=100mm 180 degree orientation	8-25-0912	Contact us
MHF 4-4 harness OD=0.81mm L=200mm 180 degree orientation	8-25-0913	Contact us

Component Parts Details

MHF[®] 4 plug Ni top

Recommended P/N	20611-001R
PART NO.	
20611-001R	

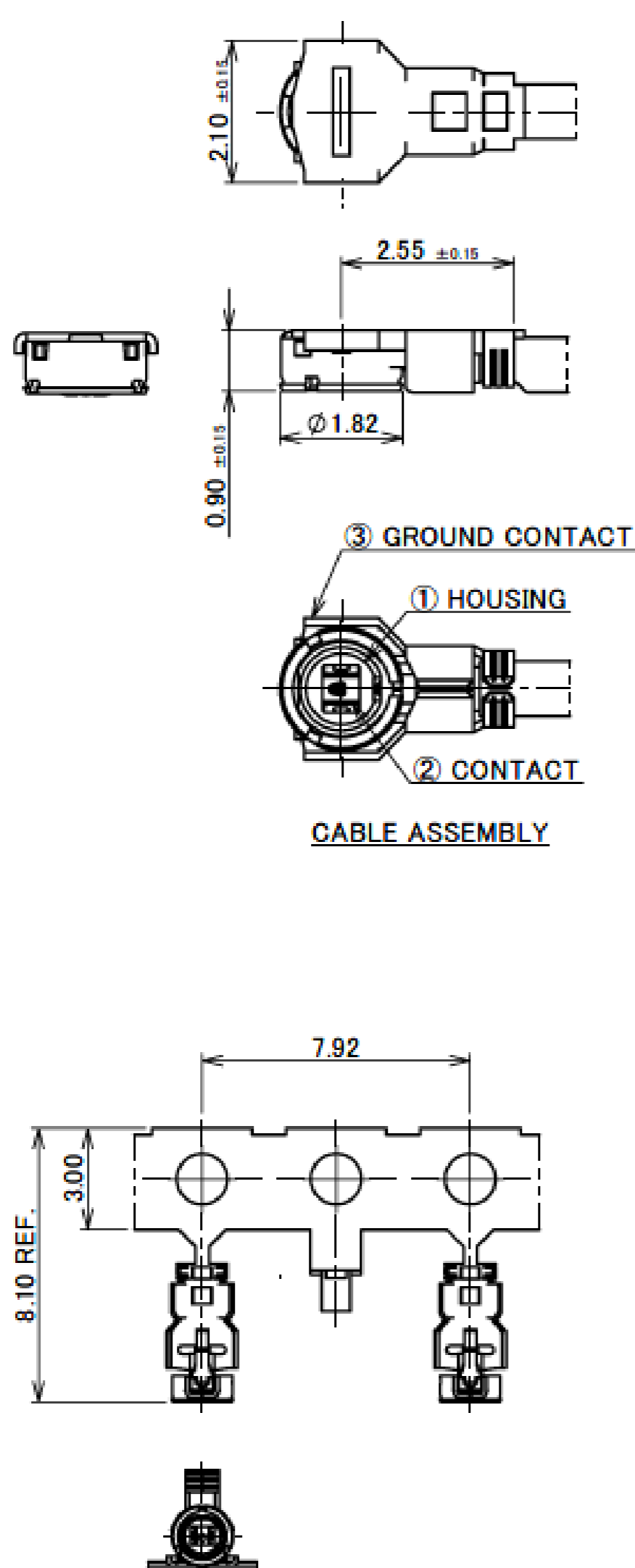

CARRIER CONDITION
S = 5:1

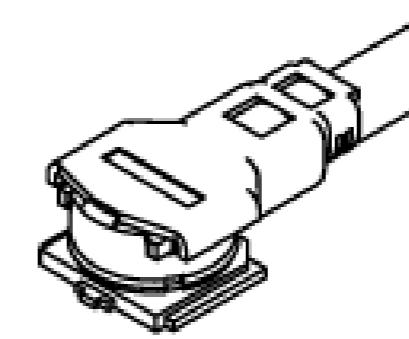
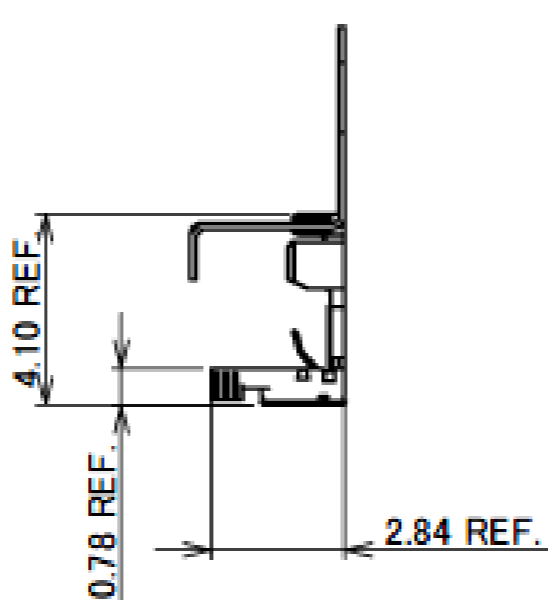
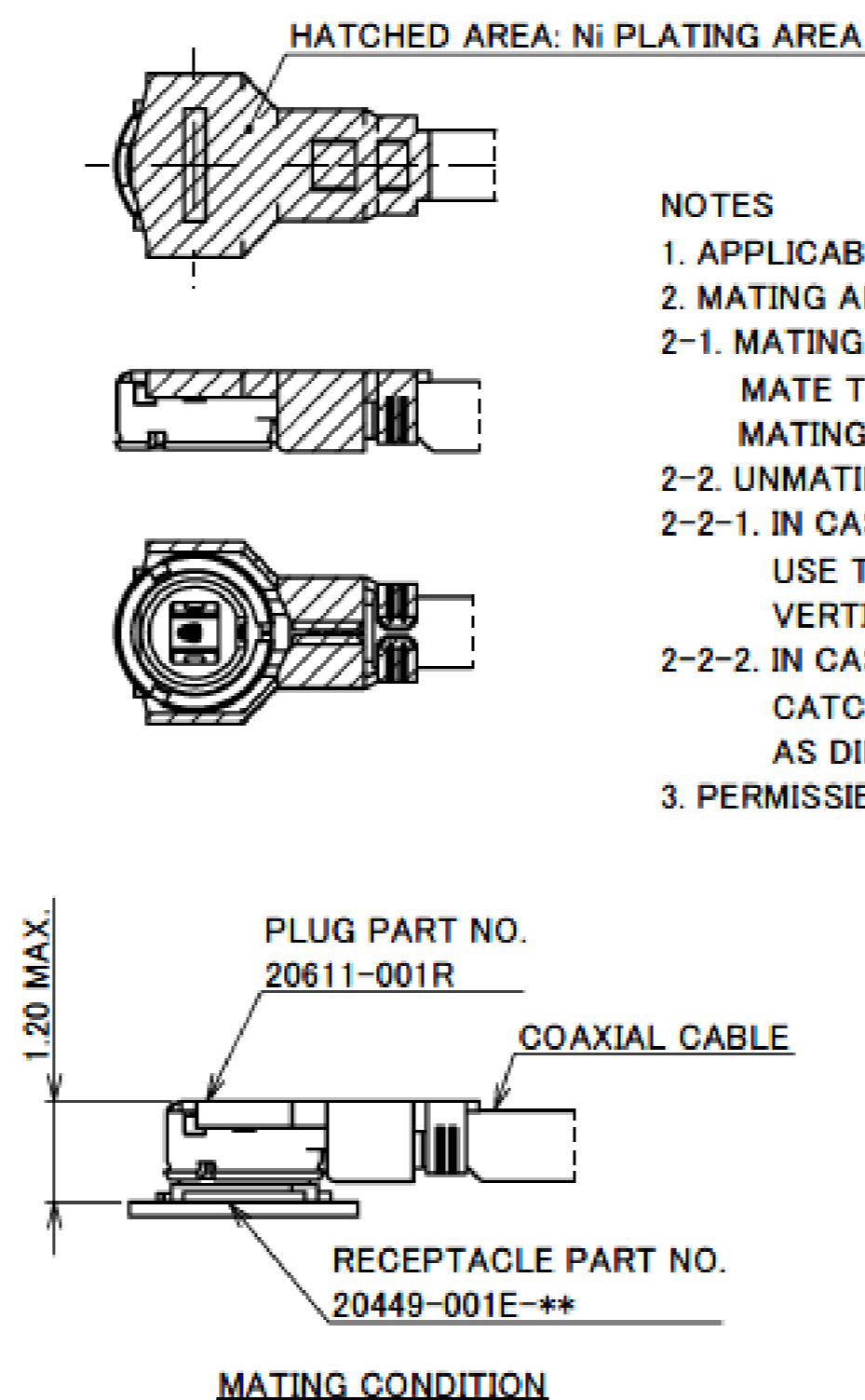

NOTES

1. APPLICABLE CONNECTOR: 20449-001E-**
2. MATING AND UNMATING INSTRUCTION
 - 2-1. MATING
MATE THE CONNECTOR VERTICALLY AS MUCH AS POSSIBLE. ADJUSTING THE MATING AXIS OF PLUG AND RECEPTACLE. DO NOT SLANT MATE.
 - 2-2. UNMATING
 - 2-2-1. IN CASE OF UNMATING BY PULLING TOOL (PART NO. 90435-001)
USE THE PULLING TOOL AS THE FOLLOWING DRAWING, AND PULL PLUG TO VERTICAL DIRECTION AS DIRECTLY AS POSSIBLE.
 - 2-2-2. IN CASE OF UNMATING DIRECTLY BY HAND.
CATCH THE CATCHING AREA OF PLUG, AND PULL TO VERTICAL DIRECTION AS DIRECTLY AS POSSIBLE.
3. PERMISSIBLE LOAD OF CABLE AT MATING

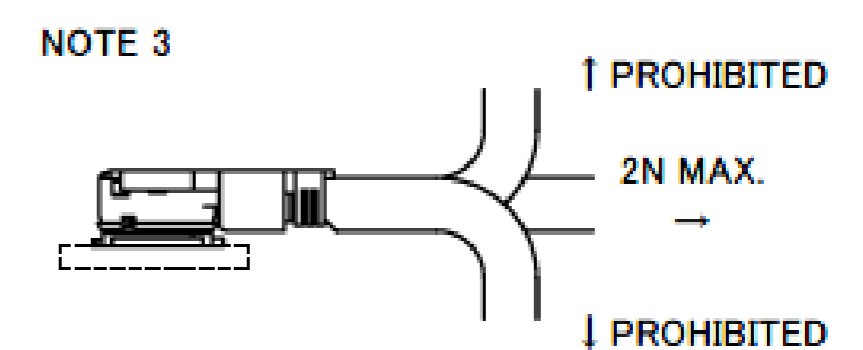
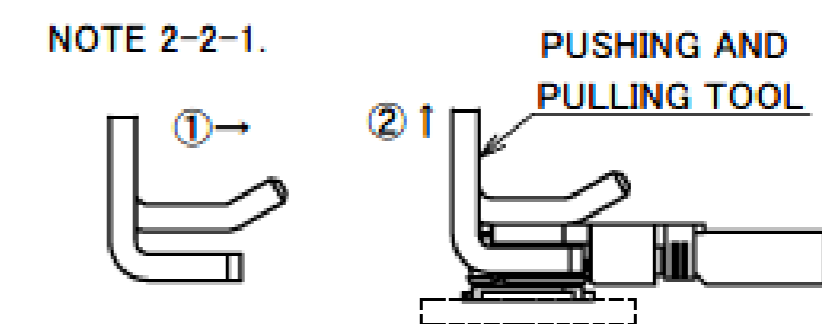
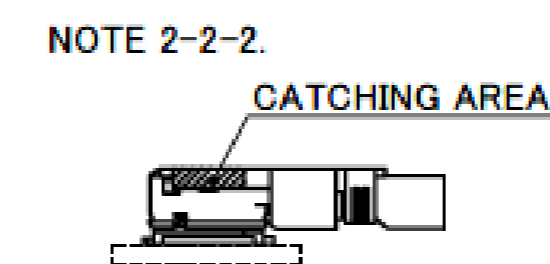
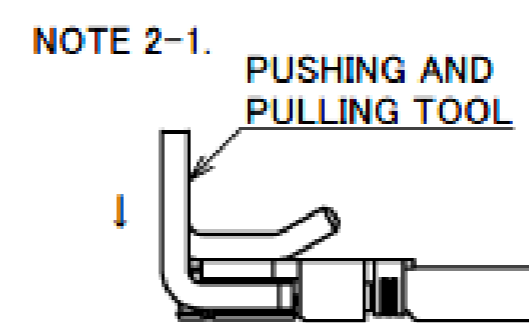

NO.	DESCRIPTION	MATERIAL	FINISH , REMARKS
3	GROUND CONTACT	PHOSPHOR BRONZE	ALL OVER: Ni 1.00 μ m MIN. CONTACT PART: Au 0.02 μ m MIN. [Ni PLATING AREA] Ni ONLY
2	CONTACT	PHOSPHOR BRONZE	ALL OVER: Ni 1.00 μ m MIN. CONTACT PART: Au 0.03 μ m MIN.
1	HOUSING	PBT	UL94V-0, BLACK

MHF[®] 4 plug Ni top

ITEMS	SPECIFICATION
APPLICABLE CONNECTOR PART NO.	20449-001E-**
RATING VOLTAGE	60 V AC (R.M.S) / DC
RATING FREQUENCY	DC~9GHz
OPERATING TEMPERATURE	233~363 K (-40°C~+90°C)
VSWR (MATED WITH SMA ADAPTER PART No. 90449-001)	1.30 MAX. AT 0.1~3GHz, 1.50 MAX. AT 3~6GHz, 2.00 MAX. AT 6~9GHz
MAIN CONTACT RESISTANCE	INITIAL: 20 mohm MAX. / AFTER TEST: Δ R 20 mohm MAX.
GROUND CONTACT RESISTANCE	INITIAL: 20 mohm MAX. / AFTER TEST: Δ R 100 mohm MAX.
INSULATION RESISTANCE	INITIAL: 500 Mohm MIN. / AFTER TEST: 100 Mohm MIN.
DIELECTRIC WITHSTANDING VOLTAGE	200 V AC 1 MINUTE
DURABILITY	30 CYCLES
UNMATING FORCE (INITIAL / AFTER TEST)	INITIAL: 4 N MIN. / AFTER TEST: 2 N MIN.
CRIMP STRENGTH	5 N MIN.
PRODUCT SPECIFICATION	PRS-2530
TEST REPORT	TR-18086
PACKING STANDARD	300-591
INSTRUCTION MANUAL	HIM-10003
APPEARANCE CRITERIA No.	QLS-A***

Rev.3

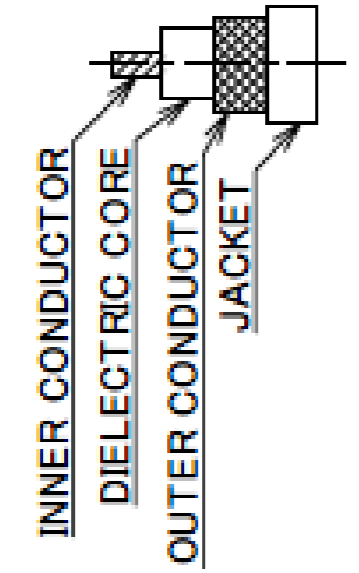
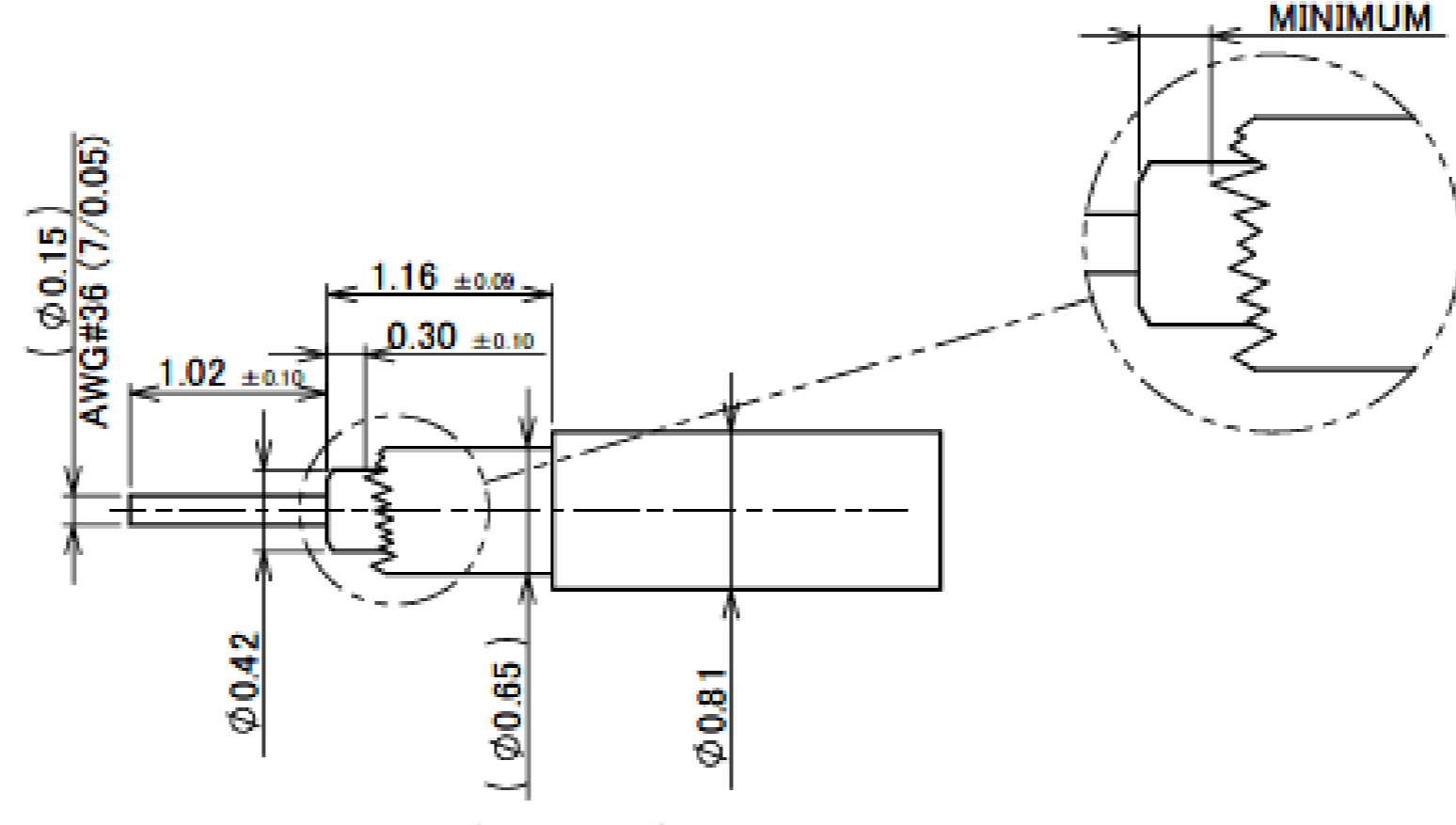
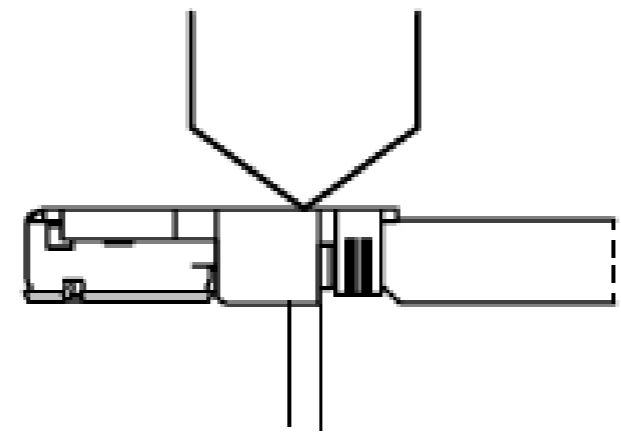
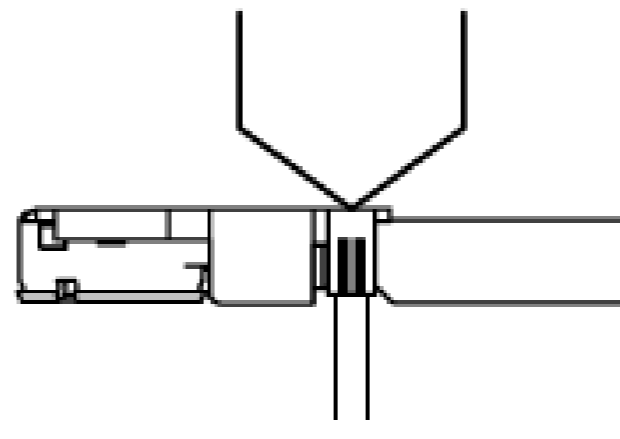
PART No.	20611-001R	
<p>APPLICABLE CABLE STRIP DIMENSION</p>  <p>INNER CONDUCTOR DIELECTRIC CORE OUTER CONDUCTOR JACKET</p>	 <p>SEE NOTE 4. (S = 20 : 1)</p>	
BRAIDED SHIELD OF OUTER CONDUCTOR	SINGLE BRAIDED SHIELD	
CRIMP HEIGHT	 <p>SEE NOTE 5.</p> <p>i-Fit[®] PART 0.91~0.94</p>	 <p>SEE NOTE 5.</p> <p>JACKET PART 0.82~0.85</p>

NOTES.
4. MUST NOT USE SOLDER COATED INNER CONDUCTOR AND OUTER CONDUCTOR.
5. USE POINT MICROMETER.

Rev.3

MHF[®] 4 plug Au

Recommended P/N	20448-001R-081
PART NO.	20448-001R-081

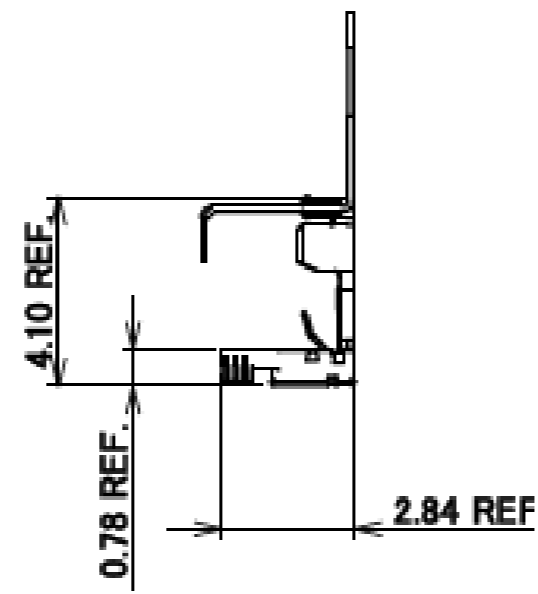
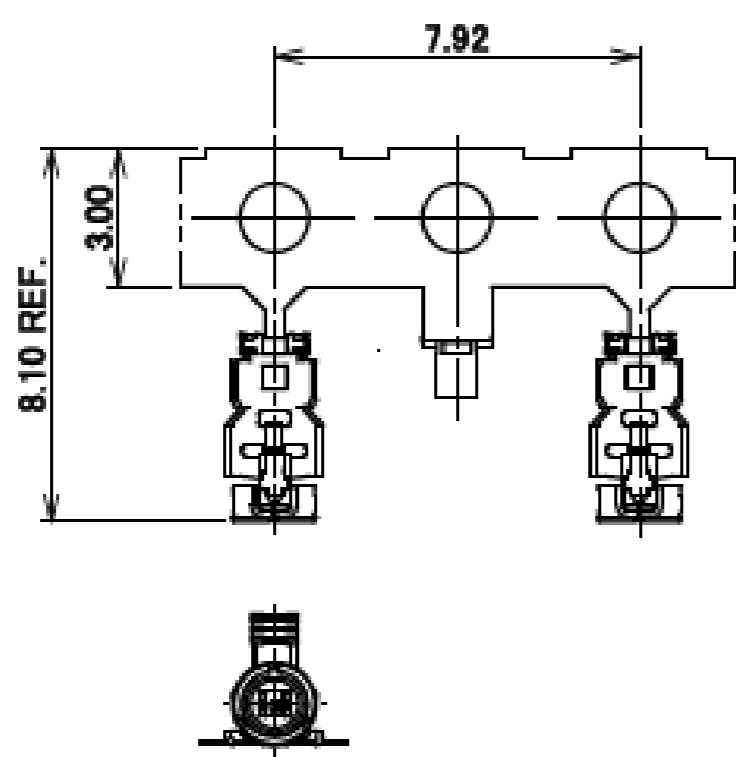
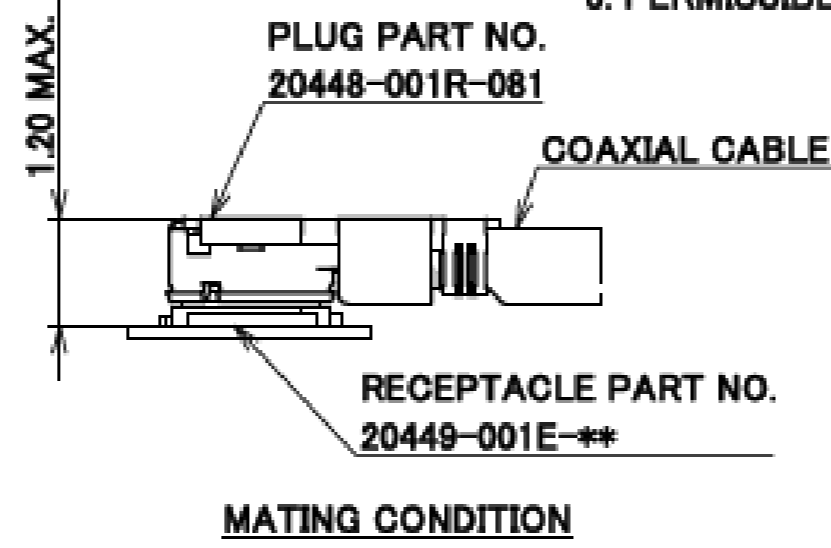
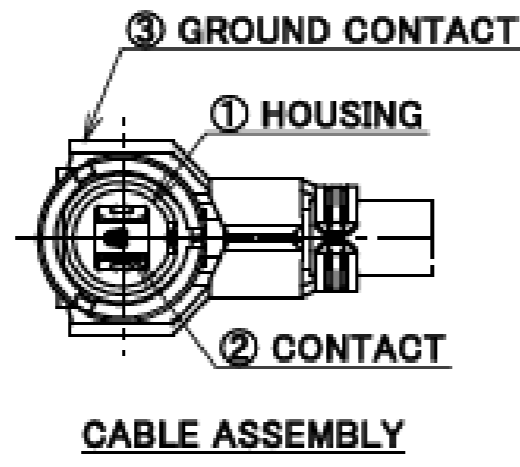
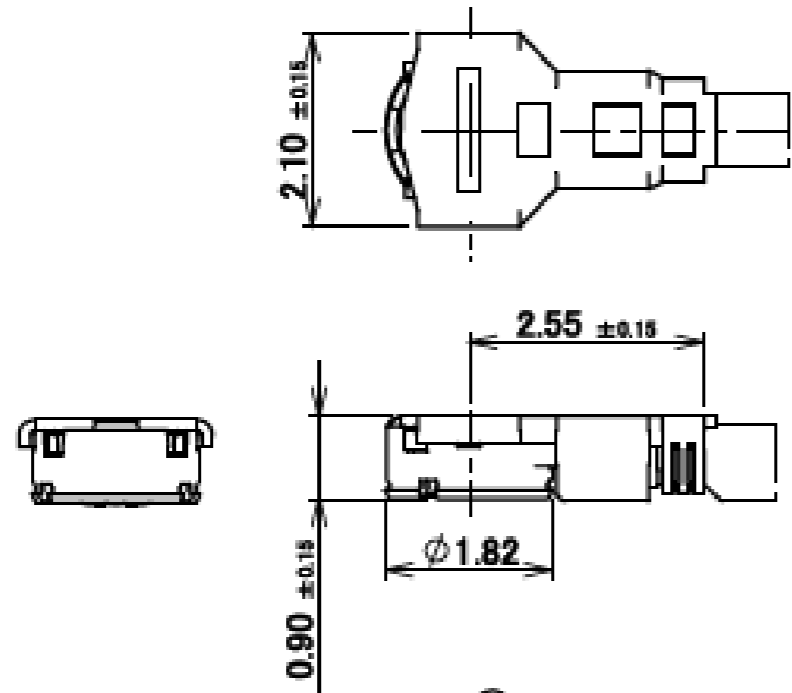

CARRIER CONDITION
S = 5:1

NOTES

1. APPLICABLE CONNECTOR: 20449-001E-**
2. MATING AND UNMATING INSTRUCTION

2-1. MATING

MATE THE CONNECTOR VERTICALLY AS MUCH AS POSSIBLE. ADJUSTING THE MATING AXIS OF PLUG AND RECEPTACLE. DO NOT SLANT MATE.

2-2. UNMATING

2-2-1. IN CASE OF UNMATING BY PULLING TOOL (PART NO. 90435-001)

USE THE PULLING TOOL AS THE FOLLOWING DRAWING, AND PULL PLUG TO VERTICAL DIRECTION AS DIRECTLY AS POSSIBLE.

2-2-2. IN CASE OF UNMATING DIRECTLY BY HAND.

CATCH THE CATCHING AREA OF PLUG, AND PULL TO VERTICAL DIRECTION AS DIRECTLY AS POSSIBLE.

3. PERMISSIBLE LOAD OF CABLE AT MATING

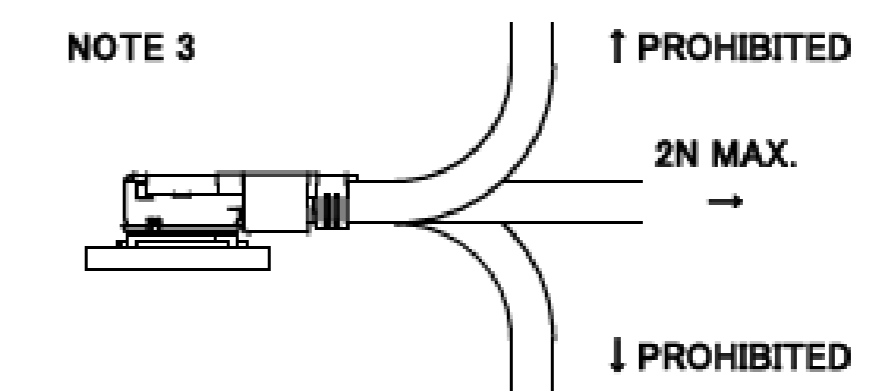
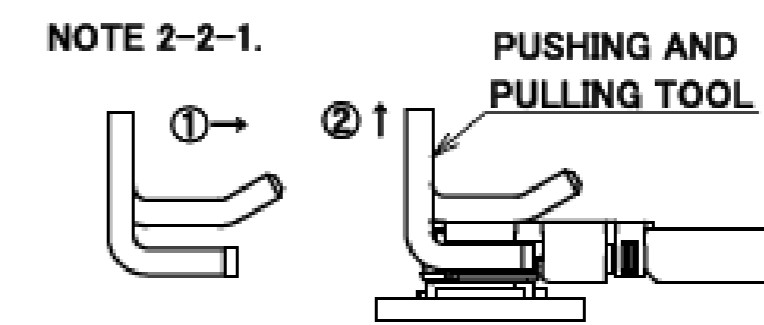
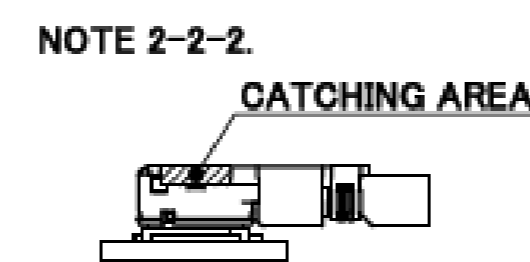
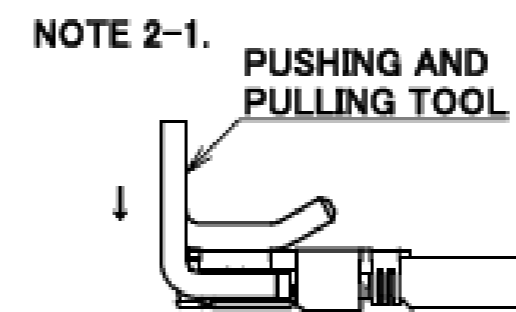
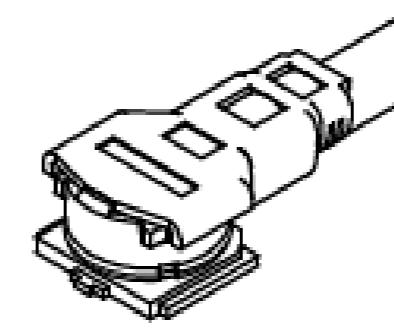

NO.	DESCRIPTION	MATERIAL	FINISH, REMARKS
3	GROUND CONTACT	PHOSPHOR BRONZE	ALL OVER: Ni 1.00 μm MIN. CONTACT PART: Au 0.05 μm MIN.
2	CONTACT	PHOSPHOR BRONZE	ALL OVER: Ni 1.00 μm MIN. CONTACT PART: Au 0.30 μm MIN.
1	HOUSING	PBT	UL94V-0, BLACK

ITEMS	SPECIFICATION
APPLICABLE CONNECTOR PART NO.	20449-001E-**
RATING VOLTAGE	60 V AC (R.M.S) / DC
RATING FREQUENCY	DC~9GHz
OPERATING TEMPERATURE	233~383 K (-40°C~+90°C)
VSWR (MATED WITH SMA ADAPTER PART No. 90449-001)	1.30 MAX. AT 0.1~3GHz, 1.50 MAX. AT 3~6GHz, 2.00 MAX. AT 6~9GHz
MAIN CONTACT RESISTANCE	INITIAL: 20 mohm MAX. / AFTER TEST: \leq R 20 mohm MAX.
GROUND CONTACT RESISTANCE	INITIAL: 20 mohm MAX. / AFTER TEST: \leq R 20 mohm MAX.
INSULATION RESISTANCE	INITIAL: 500 Mohm MIN. / AFTER TEST: 100 Mohm MIN.
DIELECTRIC WITHSTANDING VOLTAGE	200 V AC 1 MINUTE
DURABILITY	30 CYCLES
UNMATING FORCE (INITIAL / AFTER TEST)	INITIAL: 4 N MIN. / AFTER TEST: 2 N MIN.
CRIMP STRENGTH	5 N MIN.
PRODUCT SPECIFICATION	PRS-1745
TEST REPORT	TR-12118
PACKING STANDARD	300-591
INSTRUCTION MANUAL	HIM-10003
APPEARANCE CRITERIA No.	QLS-A***

Rev.7

MHF[®] 4 plug Au

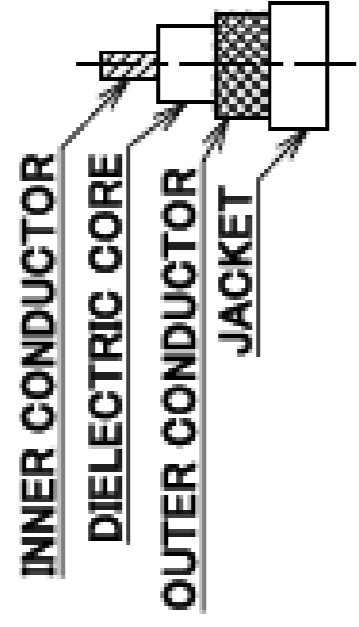
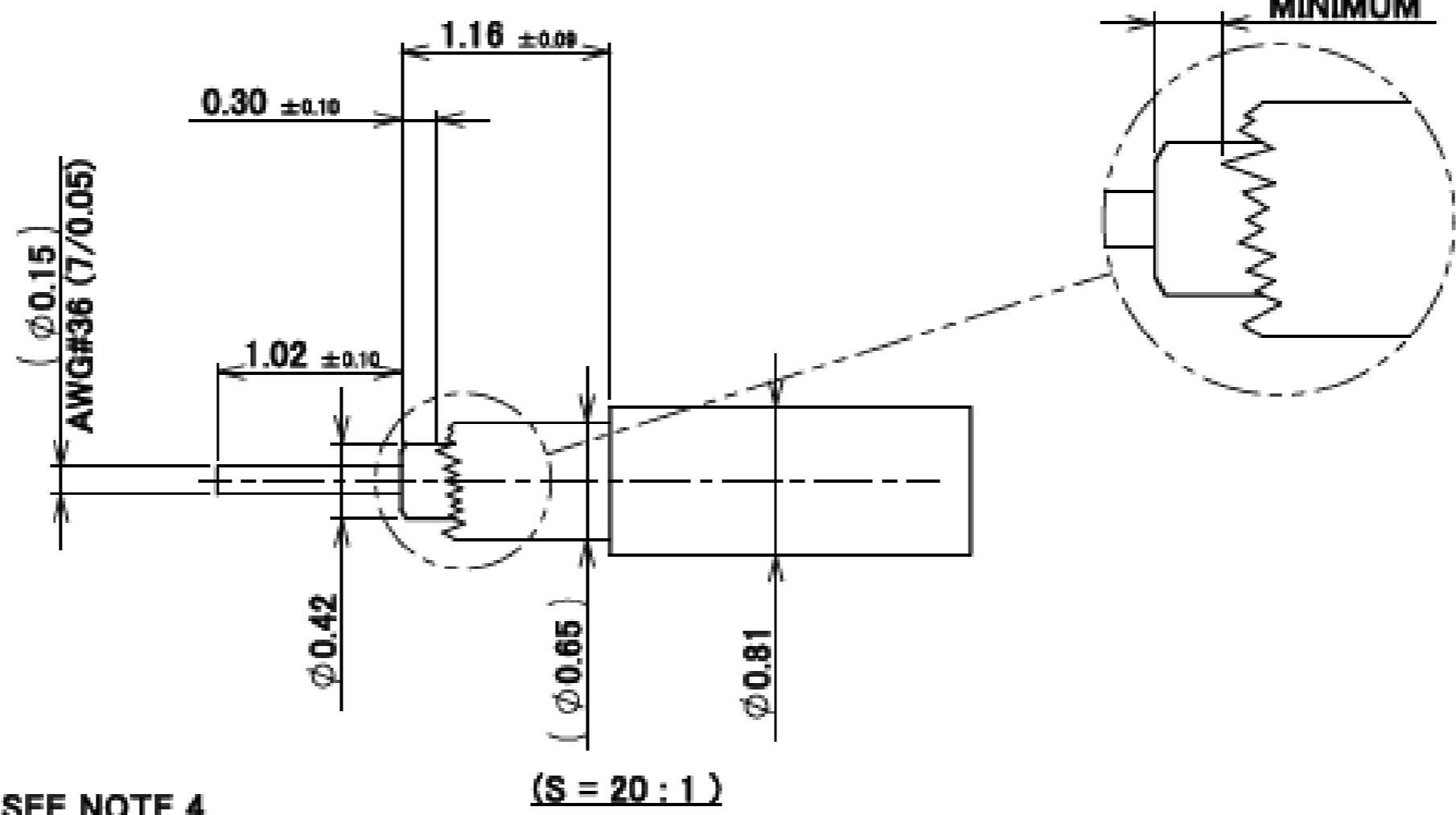
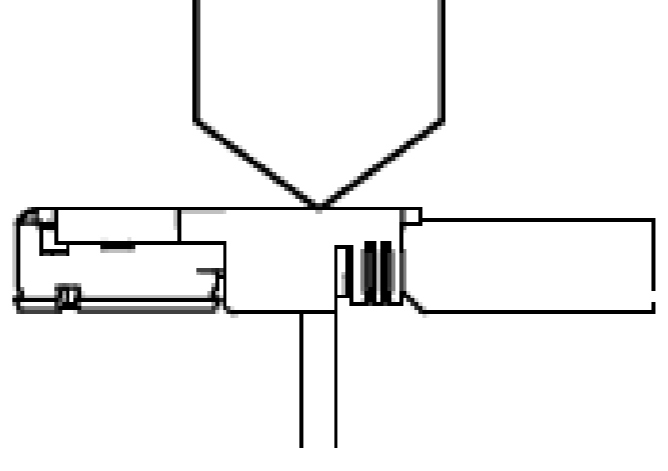
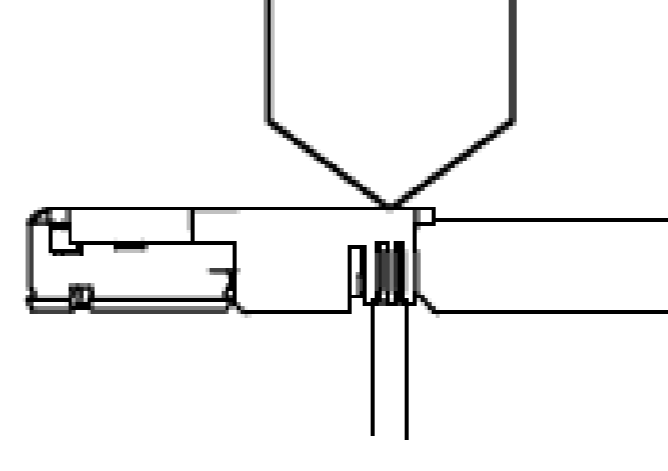
PART No.	20448-001R-081	
<p>APPLICABLE CABLE STRIP DIMENSION</p> 	 <p>* SEE NOTE 4. (S = 20 : 1)</p>	
BRAIDED SHIELD OF OUTER CONDUCTOR	SINGLE BRAIDED SHIELD	
CRIMP HEIGHT	 <p>* SEE NOTE 5.</p> <p>i-Fit[®] PART 0.91~0.94</p>	 <p>* SEE NOTE 5.</p> <p>JACKET PART 0.82~0.85</p>

NOTES.
4. MUST NOT USE SOLDER COATED INNER CONDUCTOR /
5. USE POINT MICROMETER.

Rev.7

Accessories for MHF[®] 4 plug

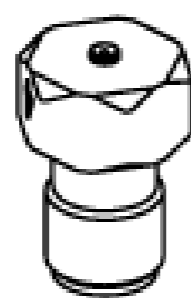

MHF 4 (4L) SMA ADAPTOR
PART NO. 90449-001



MHF 4 (4L) INSPECTION CONNECTOR
PART NO. 90449-003-01



FRONT SIDE



BACK SIDE

MHF 4 PUSHING AND PULLING TOOL
PART NO. 90435-001

MHF® 4 Receptacle

Recommended P/N 20449-001E-03

PART NO.	PACKING QUANTITY / REEL	CONTACT PLATING			GROUND CONTACT PLATING		
		CONTACT PART	SOLDERING PART	ALL OVER	CONTACT PART	SOLDERING PART	ALL OVER
20449-001E	10,000 PCS.	TOP: Au 0.05 μm MIN.	TOP OTHER: Au 0.01 μm MIN. ZONE X: Au 0.03 μm MIN.	Ni 1.00 μm MIN.	TOP: Au 0.03 μm MIN.	TOP: Au 0.01 μm MIN.	Ni 1.00 μm MIN.
20449-001E-01		TOP: Au 0.01 μm MIN. MIDDLE: Pd-Ni 0.02 μm MIN.	TOP: Au 0.01 μm MIN. MIDDLE: Pd-Ni 0.02 μm MIN.		TOP: Au 0.01 μm MIN. MIDDLE: Pd-Ni 0.02 μm MIN.	TOP: Au 0.01 μm MIN. MIDDLE: Pd-Ni 0.02 μm MIN.	
20449-001E-03							

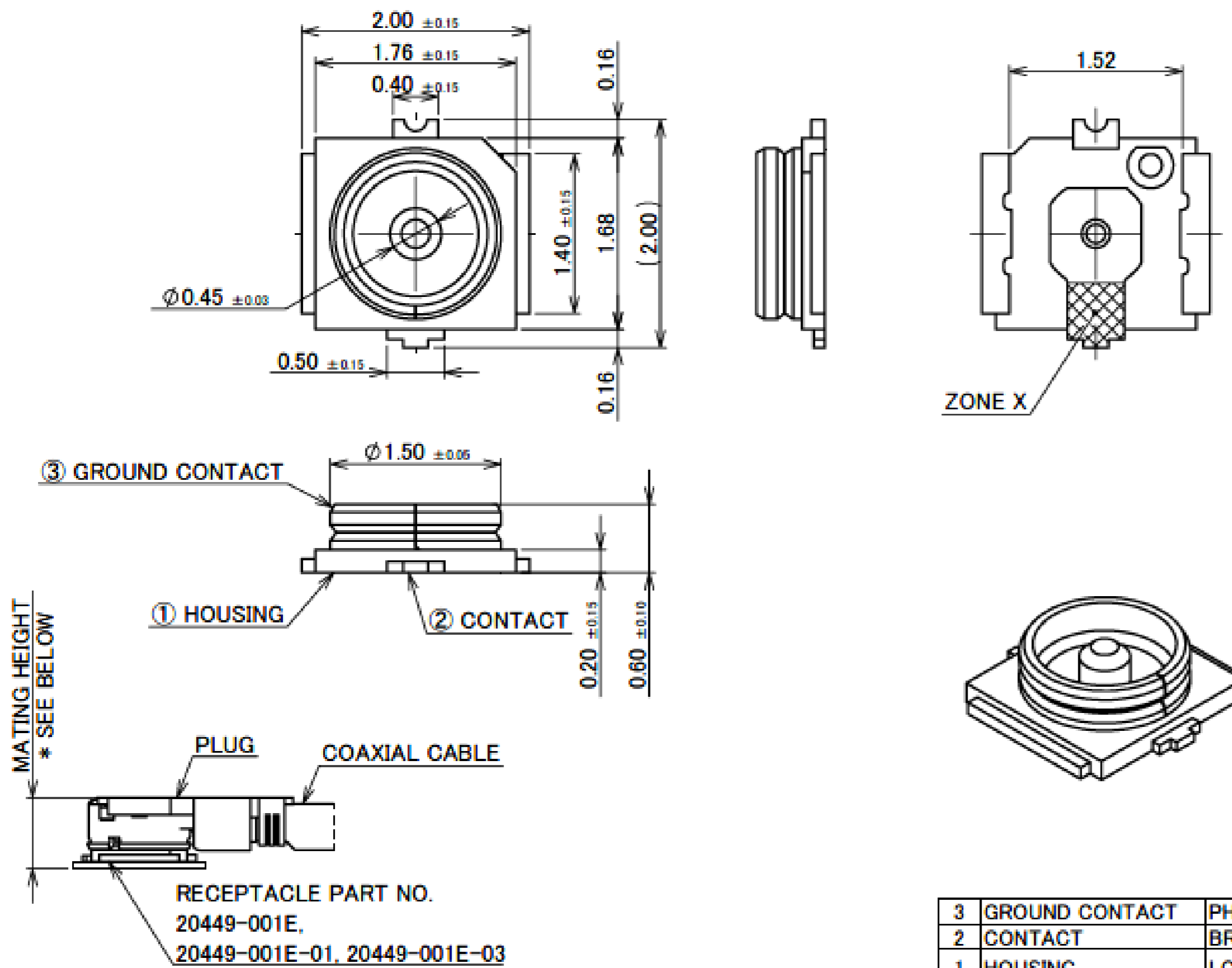
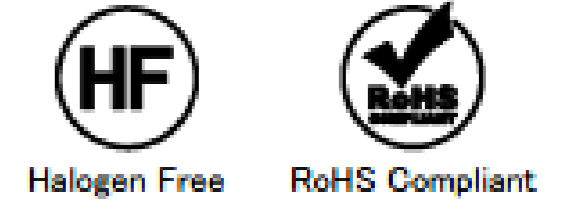

1. APPLICABLE CONNECTOR (CABLE SIZE)
 MHF 4 PLUG: 20611-001R (Φ0.81)
 20448-00*R-081 (Φ0.81)
 20448-001R-081E (Φ0.81)
 MHF 4L PLUG: 20572-001R-08 (Φ0.64, Φ0.81)
 20565-001R-** (Φ0.83, Φ0.95, Φ1.13)
 20632-001R-37 (Φ1.37)
2. COPLANARITY: 0.1 mm MAX.
3. THIS IS "Pb-FREE" CONNECTOR.
4. CHARACTERISTIC IMPEDANCE: 50 Ω (NOMINAL VALUE)

NO.	DESCRIPTION	MATERIAL	FINISH, REMARKS
3	GROUND CONTACT	PHOSPHOR BRONZE	SEE TABLE
2	CONTACT	BRASS	
1	HOUSING	LCP	UL94V-0, BLACK

* MATING HEIGHT
 1.2 MAX. WITH 20611-001R, 20572-001R-08,
 20448-00*R-081, 20448-001R-081E
 1.4 MAX. WITH 20565-001R-**
 1.7 MAX. WITH 20632-001R-37
 (2.0 MAX. WITH MHF 4L LK LOCKED CONDITION)
 MATING CONDITION
 WITH MHF 4/MHF 4L PLUG
 (S = 10 : 1)

Rev.22

FOR MHF 4 PLUG

ITEMS	SPECIFICATION	
	20611-001R (CABLE Φ0.81 TYPE)	20448-001R (CABLE Φ0.81 TYPE)
APPLICABLE CONNECTOR PART No.		
RATED VOLTAGE	60 V AC (R.M.S.)/DC	
RATED FREQUENCY	DC TO 9GHz	
OPERATING TEMPERATURE	233 TO 363 K (-40°C TO +90°C)	
CHARACTERISTIC IMPEDANCE	50 ohm (NOMINAL VALUE)	
VSWR (MATED WITH SMA ADAPTER PART No. 90449-002)	1.30 MAX. AT 0.1-3GHz, 1.40 MAX. AT 3-6GHz, 1.55 MAX. AT 6-9GHz	
MAIN CONTACT RESISTANCE	INITIAL : 20 mohm MAX. / AFTER TEST : ∠R 20 mohm MAX.	
GROUND CONTACT RESISTANCE	INITIAL : 20 mohm MAX. / AFTER TEST : ∠R 100 mohm MAX.	INITIAL : 20 mohm MAX. / AFTER TEST : ∠R 20 mohm MAX.
INSULATION RESISTANCE	INITIAL : 500 Mohm MIN. / AFTER TEST : 100 Mohm MIN.	
DIELECTRIC WITHSTANDING VOLTAGE	200 V AC 1 MINUTE	
DURABILITY	30 CYCLES	
MATING FORCE (INITIAL / AFTER TEST)	-	
UNMATING FORCE (INITIAL / AFTER TEST)	INITIAL : 4 N MIN. / AFTER TEST : 2 N MIN.	
PRODUCT SPECIFICATION	PRS-2530	PRS-1745
TEST REPORT	TR-18086	TR-12118
PACKING STANDARD	300-604	
INSTRUCTION MANUAL	HIM-10003	
APPEARANCE CRITERIA No.	QLS-A***	

MHF[®] 4 Receptacle

FOR MHF 4L PLUG

ITEMS	SPECIFICATION			
APPLICABLE CONNECTOR PART No.	20572-001R-08 (CABLE Φ0.64 TYPE) (CABLE Φ0.81 TYPE)	20565-001E-13 (CABLE Φ0.95 TYPE) (CABLE Φ1.13 TYPE)	20565-001R-83 (CABLE Φ0.83 TYPE)	20632-001R-37 (CABLE Φ1.37 TYPE)
RATED VOLTAGE	60 V AC (R.M.S)/DC			
RATED FREQUENCY	DC TO 9GHz			
OPERATING TEMPERATURE	233 TO 363 K (-40°C TO +90°C)			
CHARACTERISTIC IMPEDANCE	50 ohm (NOMINAL VALUE)			
VSWR (MATED WITH SMA ADAPTER PART No. 90449-002)	1.30 MAX. AT 0.1-3GHz, 1.40 MAX. AT 3-6GHz, 1.55 MAX. AT 6-9GHz			
MAIN CONTACT RESISTANCE	INITIAL : 20 mohm MAX. / AFTER TEST : \angle R 20 mohm MAX.			
GROUND CONTACT RESISTANCE	INITIAL : 20 mohm MAX. / AFTER TEST : \angle R 20 mohm MAX.			
INSULATION RESISTANCE	INITIAL : 500 Mohm MIN. / AFTER TEST : 100 Mohm MIN.			
DIELECTRIC WITHSTANDING VOLTAGE	200 V AC 1 MINUTE			
DURABILITY	30 CYCLES			
MATING FORCE (INITIAL / AFTER TEST)	INITIAL : 30 N MAX. / AFTER TEST : 30 N MAX.			
UNMATING FORCE (INITIAL / AFTER TEST)	INITIAL : 20 N MAX. 5 N MIN. / AFTER TEST : 20 N MAX. 3 N MIN.			
PRODUCT SPECIFICATION	PRS-1944 (CABLE Φ0.64 TYPE) PRS-1772 (CABLE Φ0.81 TYPE)	PRS-2051 (CABLE Φ0.95 TYPE) PRS-1772 (CABLE Φ1.13 TYPE)	PRS-2062 (CABLE Φ0.83 TYPE)	PRS-2008 (CABLE Φ1.37 TYPE)
TEST REPORT	TR-14078 (CABLE Φ0.64 TYPE) TR-13011 (CABLE Φ0.81 TYPE)	TR-14142 (CABLE Φ0.95 TYPE) TR-13011 (CABLE Φ1.13 TYPE)	TR-15011 (CABLE Φ0.83 TYPE)	TR-14100 (CABLE Φ1.37 TYPE)
PACKING STANDARD	300-604			
INSTRUCTION MANUAL	HIM-12011		HIM-12012	HIM-16011
APPEARANCE CRITERIA No.	QLS-A***			

Rev.22

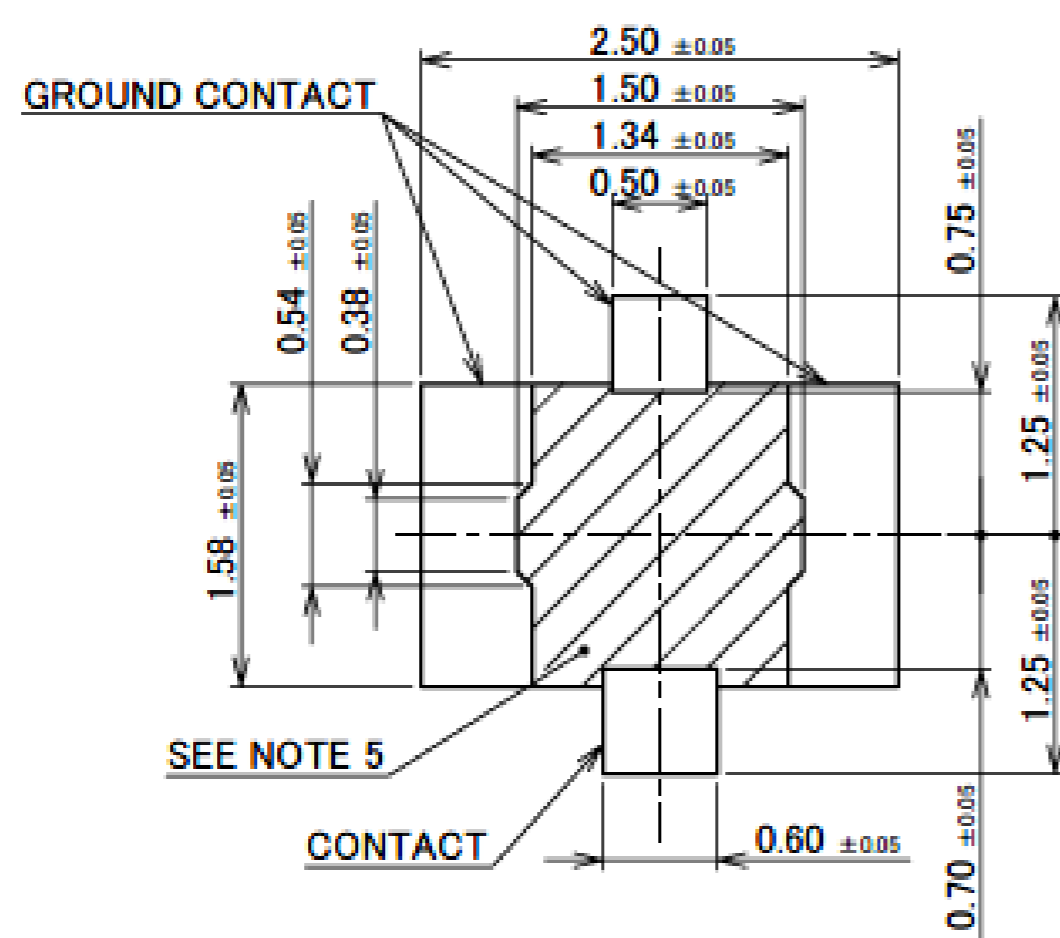

RECOMMENDED FOOTPRINT PATTERN

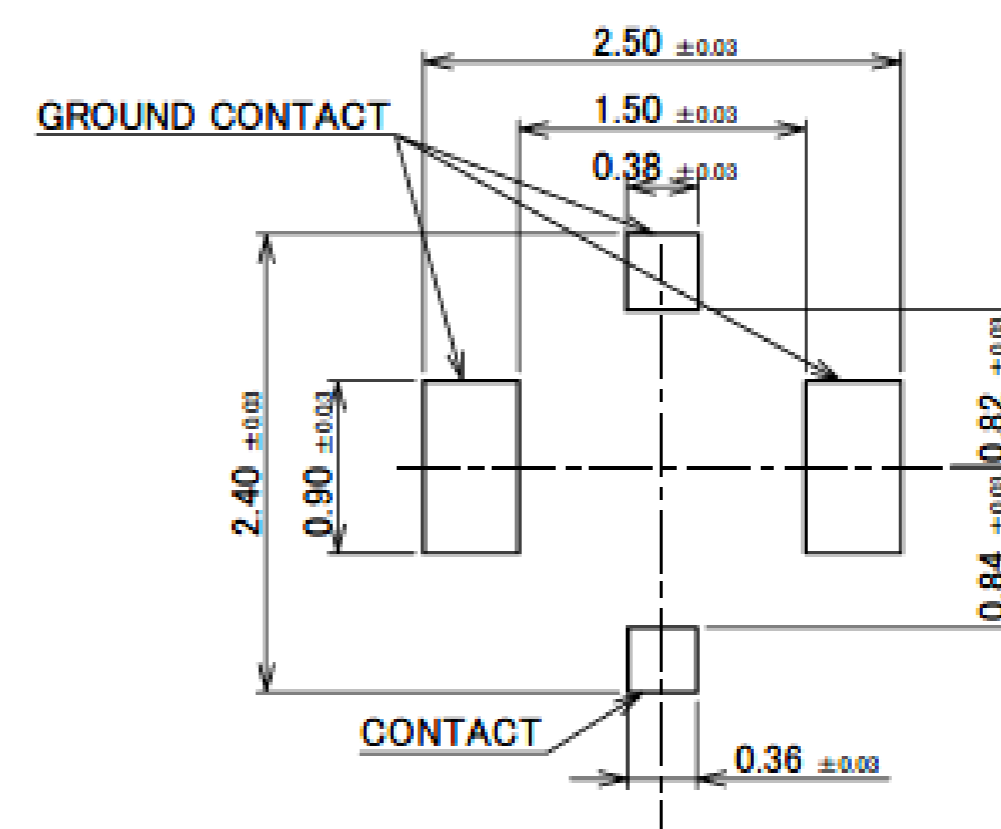

MASK THICKNESS: 0.12 mm

RECOMMENDED METAL MASK LAYOUT

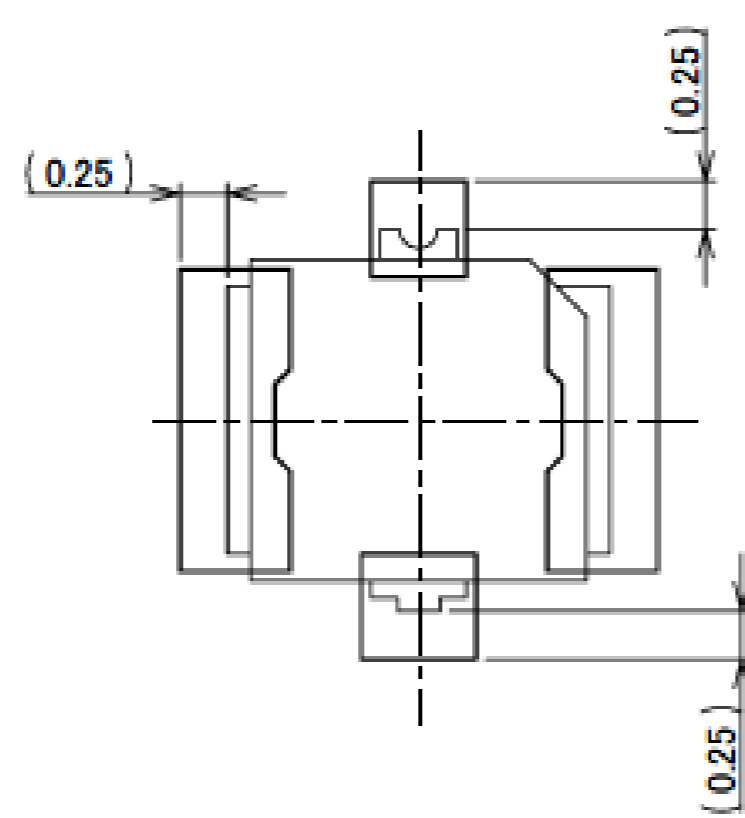

CONNECTOR ON RECOMMENDED FOOTPRINT PATTERN

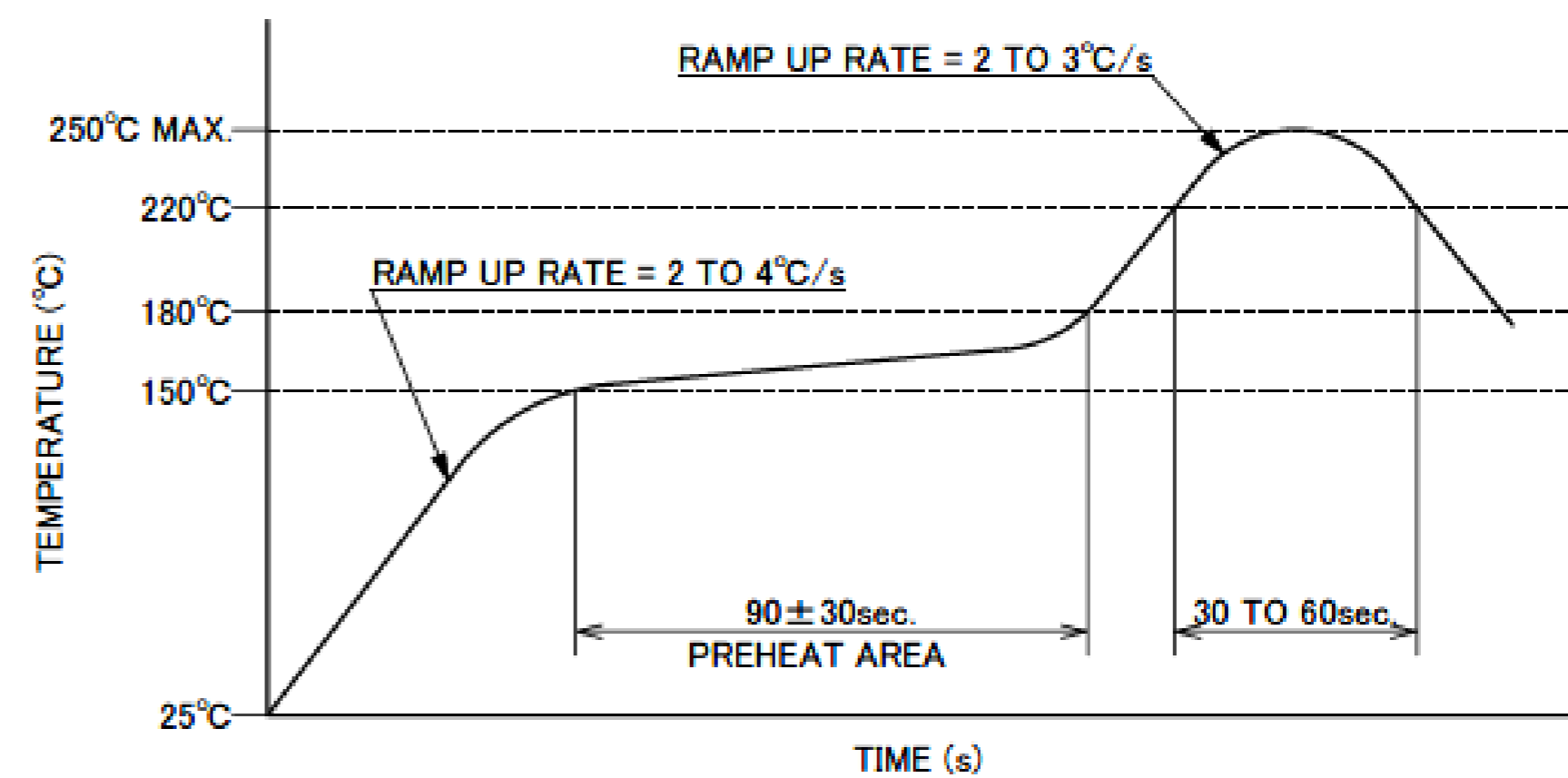

REFLOW TEMPERATURE PROFILE
SENJU METAL INDUSTRY CO., LTD. : M705-SHF(Sn96.5 Ag3.0 Cu0.5)

NOTE 5. NO GROUND, SIGNAL, AND RESIST ALLOWED IN THIS AREA.

Rev.22

MHF® 4 Receptacle

COMPONENT PLACEMENT PROHIBITED AREA FOR MHF 4 RECEPTACLE MATED WITH MHF 4L LK HARNESS REQUIRED AREA FOR RECOMMENDED JIG TO OPERATE

SINGLE CONNECTOR LAYOUT

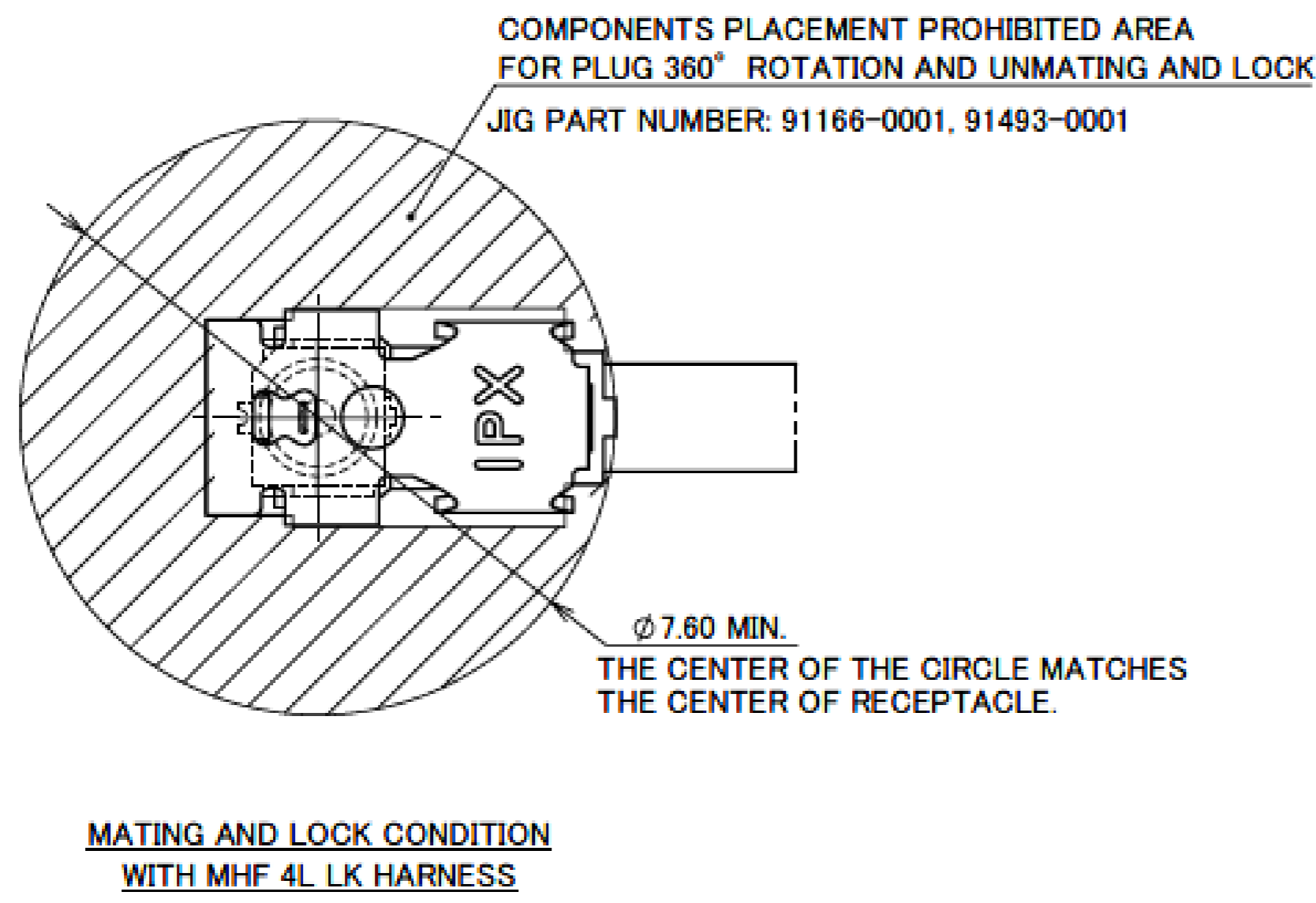

MULTIPLE CONNECTORS LAYOUT

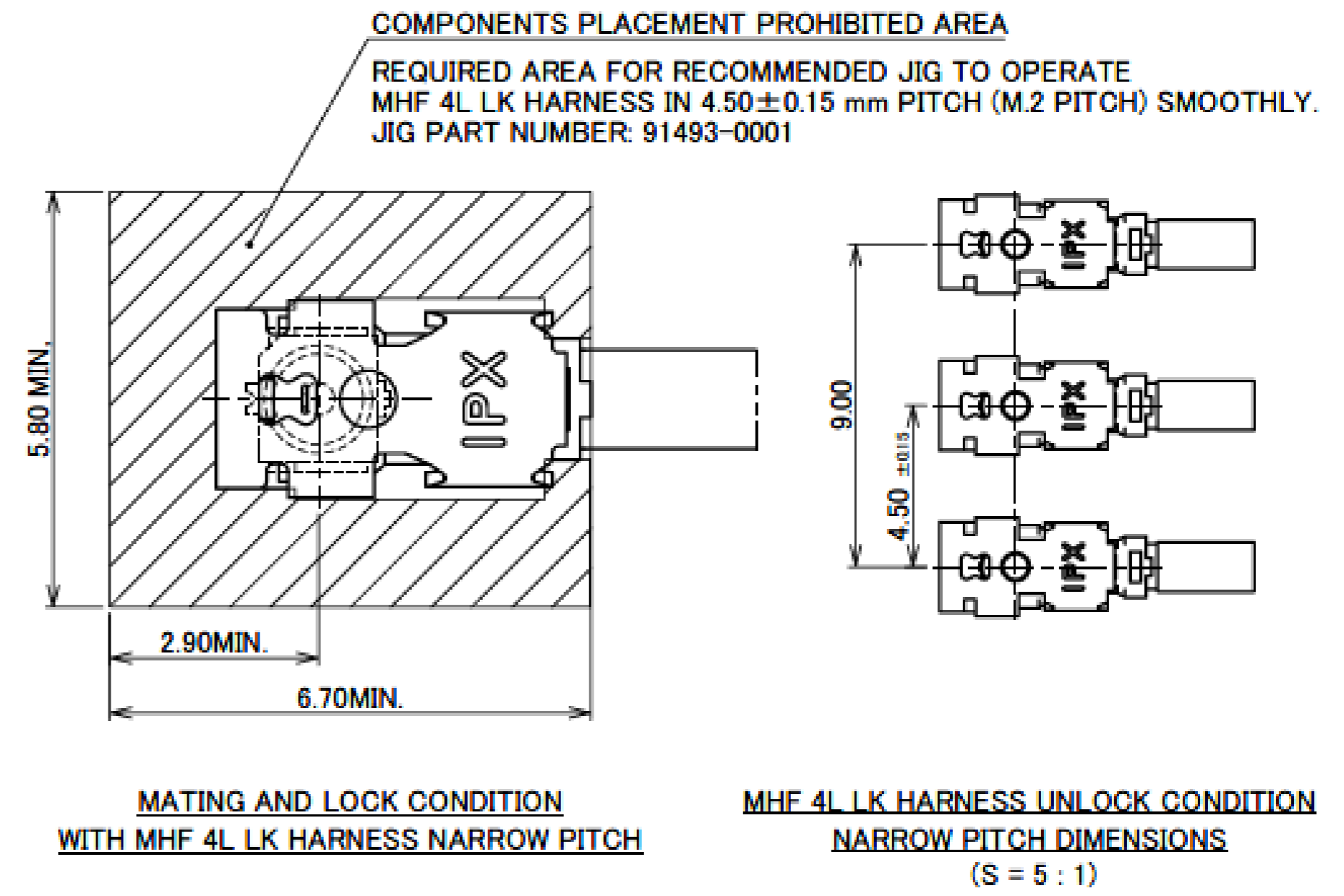

Rev.22

MHF® 4L Receptacle

Recommended P/N	20579-001E
PART NO.	PACKING QUANTITY / REEL
20579-001E	10,000 PCS.
20579-001E-01	20,000 PCS.

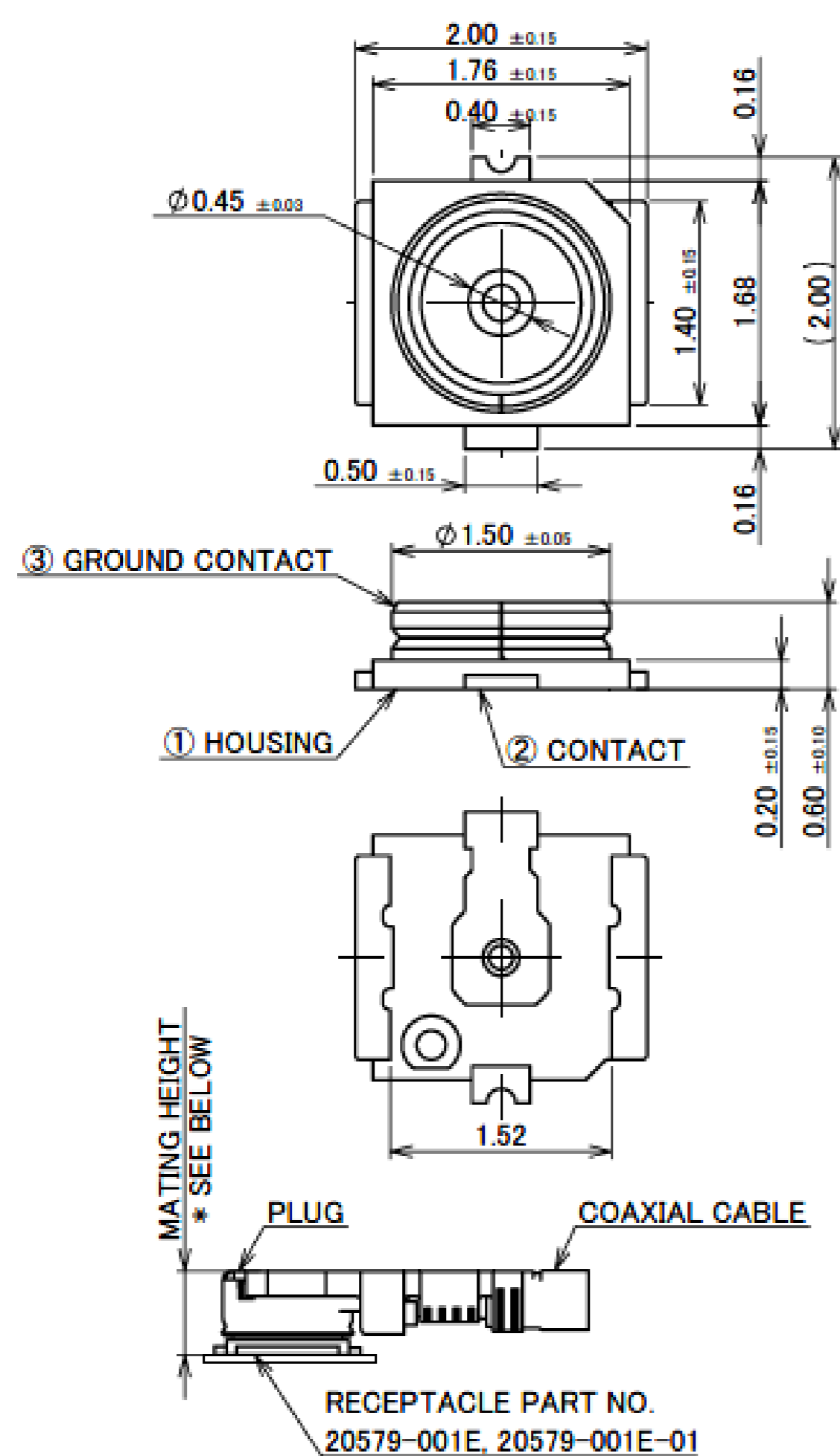

SMT Au PLATING AREA
(GROUND CONTACT)

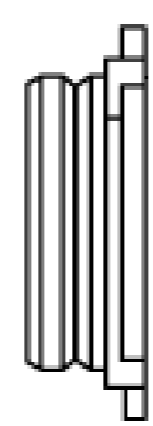

SMT Au PLATING AREA
(CONTACT)

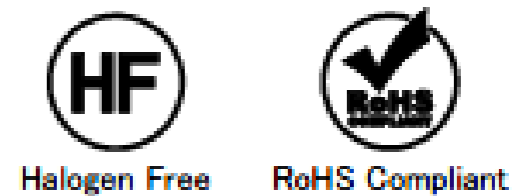
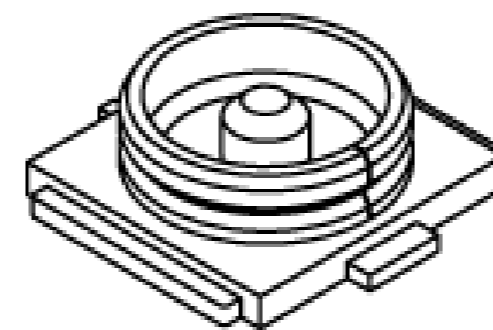

NOTES.

- APPLICABLE CONNECTOR (CABLE SIZE)
 - MHF 4 PLUG: 20611-001R (∅ 0.81)
 - 20448-00*R-081 (∅ 0.81)
 - 20448-001R-081E (∅ 0.81)
 - MHF 4L PLUG: 20572-001R-08 (∅ 0.64, ∅ 0.81)
 - 20565-001R-** (∅ 0.83, ∅ 0.95, ∅ 1.13)
 - 20632-001R-37 (∅ 1.37)
- COPLANARITY: 0.1 mm MAX.

NO.	DESCRIPTION	MATERIAL	FINISH, REMARKS
3	GROUND CONTACT	PHOSPHOR BRONZE	ALL OVER Ni: 1.00 μm MIN. CONTACT PART: Au 0.05 μm MIN., SOLDERING PART Au AREA: 0.03 μm MIN.
2	CONTACT	BRASS	ALL OVER Ni: 1.00 μm MIN. CONTACT PART: Au 0.05 μm MIN. SOLDERING PART Au AREA: 0.03 μm MIN.
1	HOUSING	LCP	UL94V-0, BLACK

* MATING HEIGHT
1.2 MAX. WITH 20611-001R, 20572-001R-08,
20448-00*R-081, 20448-001R-081E
1.4 MAX. WITH 20565-001R-**
1.7 MAX. WITH 20632-001R-37
(2.0 MAX. WITH MHF 4L LK LOCKED CONDITION)

MATING CONDITION
WITH MHF 4/MHF 4L PLUG
(S = 10/1)

Rev.16

MHF[®] 4L Receptacle

FOR MHF 4L PLUG

ITEMS	SPECIFICATION		
	20572-001R-08 (CABLE Φ0.81 TYPE)	20565-001R-13 (CABLE Φ 1.13 TYPE)	20632-001R-37 (CABLE Φ 1.37 TYPE)
APPLICABLE CONNECTOR PART No.			
RATING VOLTAGE	60 V AC (R.M.S)/DC		
RATING FREQUENCY	DC ~ 12GHz		
OPERATING TEMPERATURE	233~363 K(-40°C~+90°C)		
VSWR (MATED WITH SMA ADAPTER PART No. 90449-002)	1.30 MAX. AT 0.1~3GHz, 1.40 MAX. AT 3~6GHz, 1.50 MAX. 6~9GHz, 1.65 MAX. AT 9~12GHz		
MAIN CONTACT RESISTANCE	INITIAL : 20 mohm MAX. / AFTER TEST : ΔR 20 mohm MAX.		
GROUND CONTACT RESISTANCE	INITIAL : 20 mohm MAX. / AFTER TEST : ΔR 20 mohm MAX.		
INSULATION RESISTANCE	INITIAL : 500 Mohm MIN. / AFTER TEST : 100 Mohm MIN.		
DIELECTRIC WITHSTANDING VOLTAGE	200 V AC 1 MINUTE		
DURABILITY	30 CYCLES		
MATING FORCE (INITIAL / AFTER TEST)	INITIAL : 30 N MAX. / AFTER TEST : 30 N MAX.		
UNMATING FORCE (INITIAL / AFTER TEST)	INITIAL : 20 N MAX. 5 N MIN. / AFTER TEST : 20 N MAX. 3 N MIN.		
PRODUCT SPECIFICATION	PRS-1907		PRS-2925
TEST REPORT	TR-14097		TR-24070
PACKING STANDARD	20579-001E: PST-14004 20579-001E-01: PST-14067		
INSTRUCTION MANUAL	HIM-12011	HIM-12012	HIM-16011
APPEARANCE CRITERIA No.	QLS-A***		

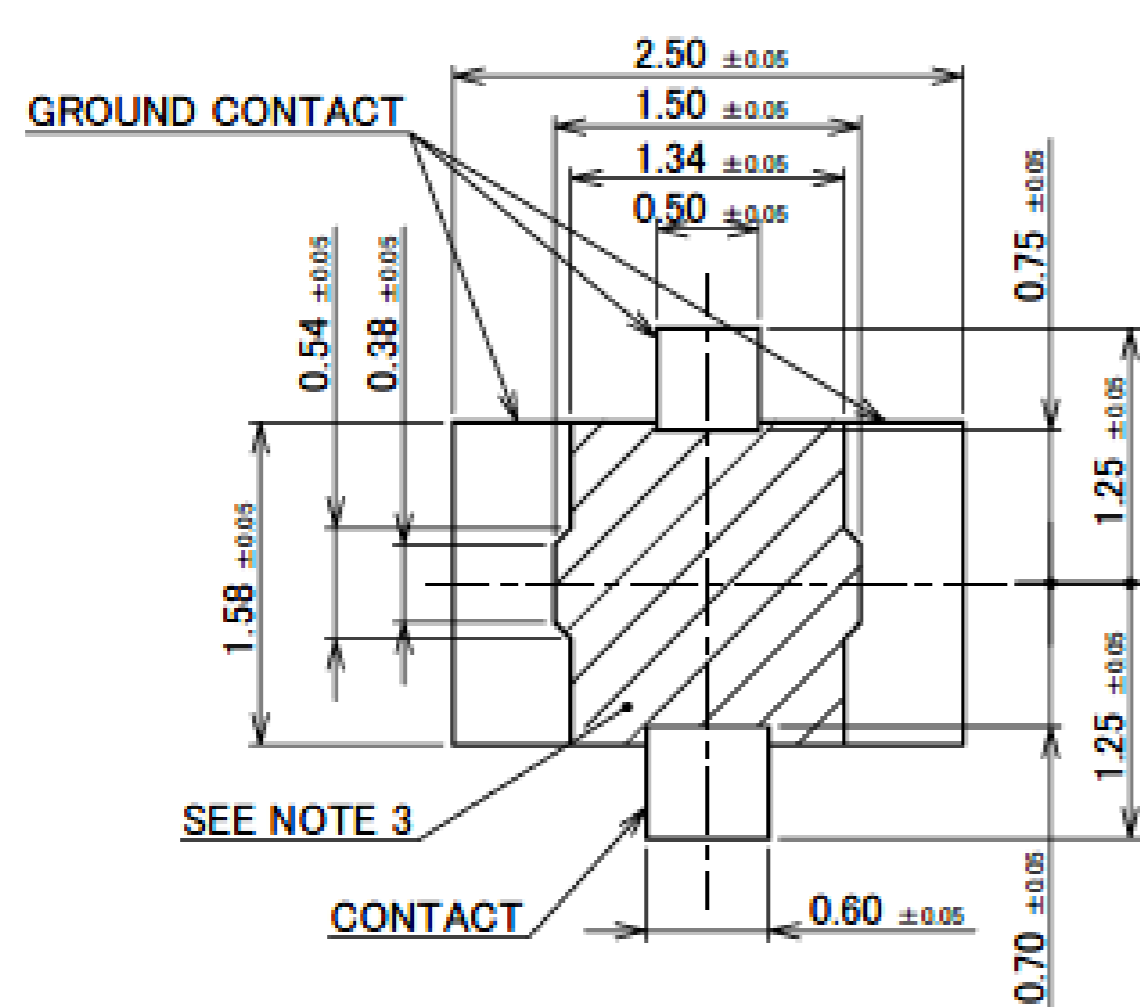

RECOMMENDED FOOTPRINT PATTERN

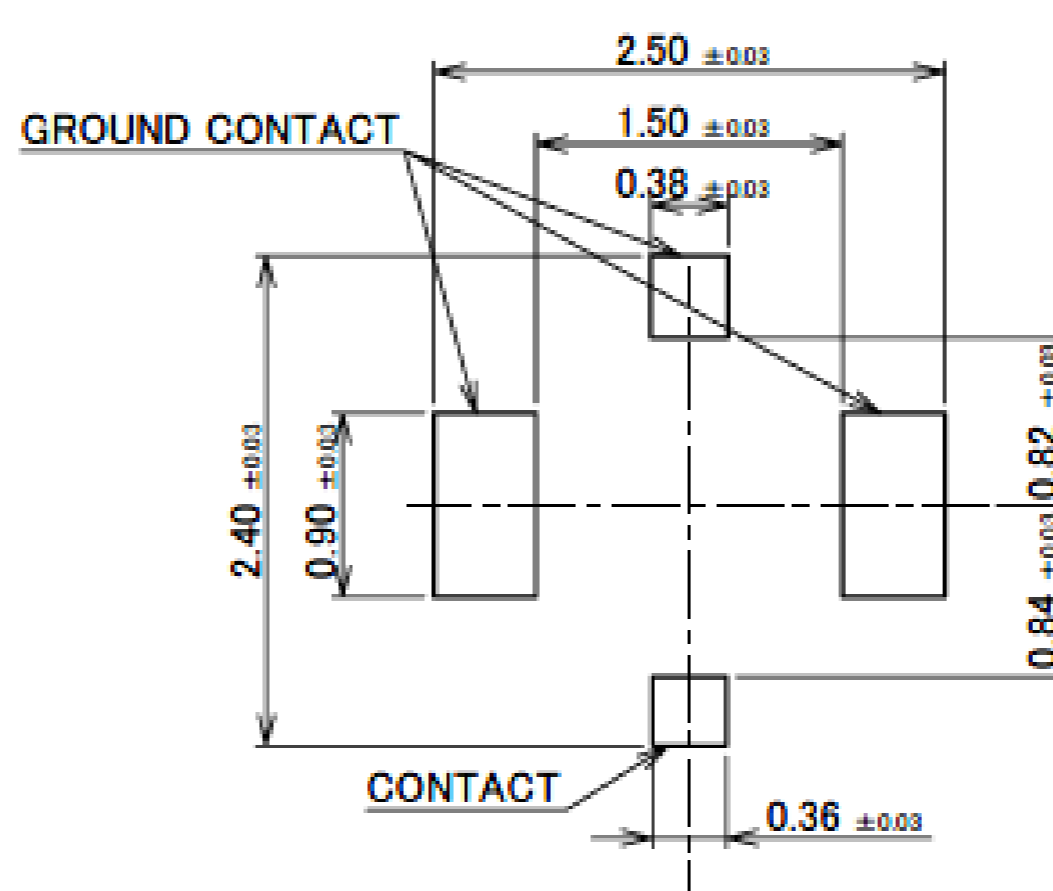

MASK THICKNESS: 0.12 mm

RECOMMENDED METAL MASK LAYOUT

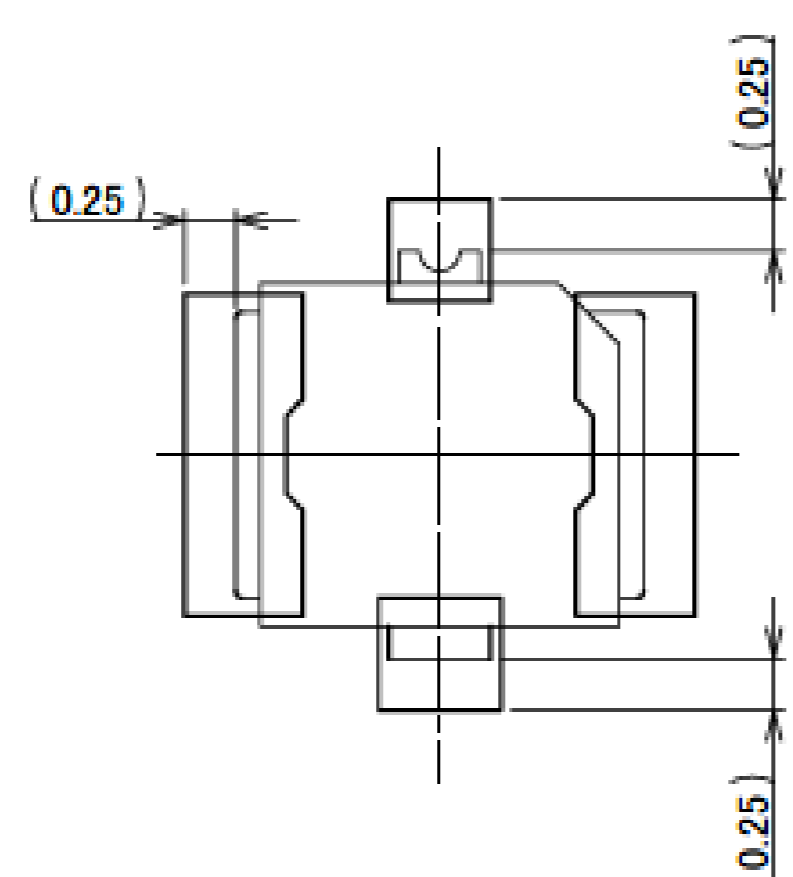

CONNECTOR ON RECOMMENDED FOOTPRINT PATTERN

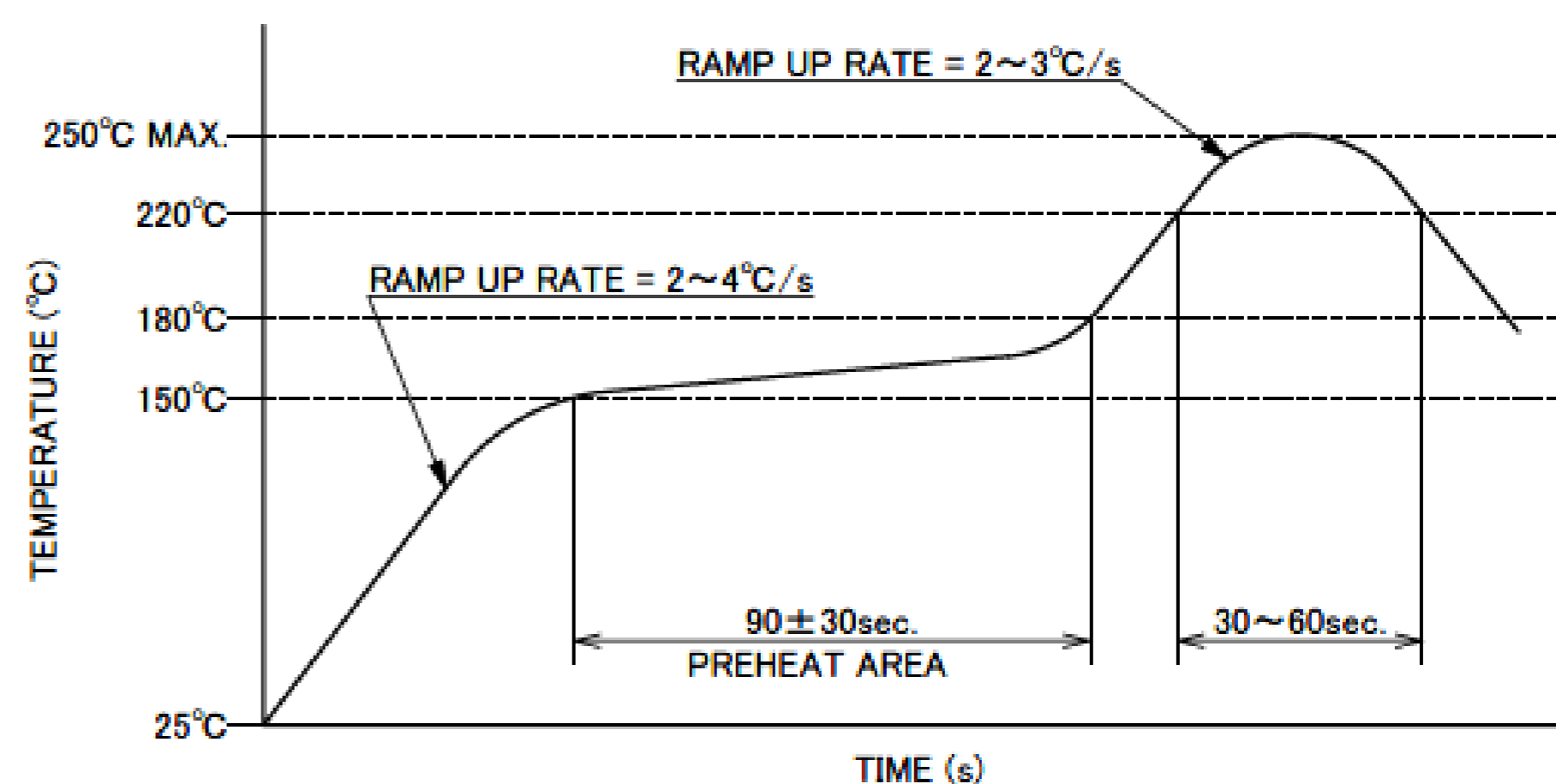

REFLOW TEMPERATURE PROFILE
SENJU METAL INDUSTRY CO., LTD. : M705-SHF(Sn96.5 Ag3.0 Cu0.5)

NOTE 3. NO GROUND, SIGNAL, AND RESIST IN THIS AREA.

Rev.16

Rev.16

MHF® 4L Receptacle

COMPONENT PLACEMENT PROHIBITED AREA FOR MHF 4L RECEPTACLE MATED WITH MHF 4L LK HARNESS REQUIRED AREA FOR RECOMMENDED JIG TO OPERATE

SINGLE CONNECTOR LAYOUT

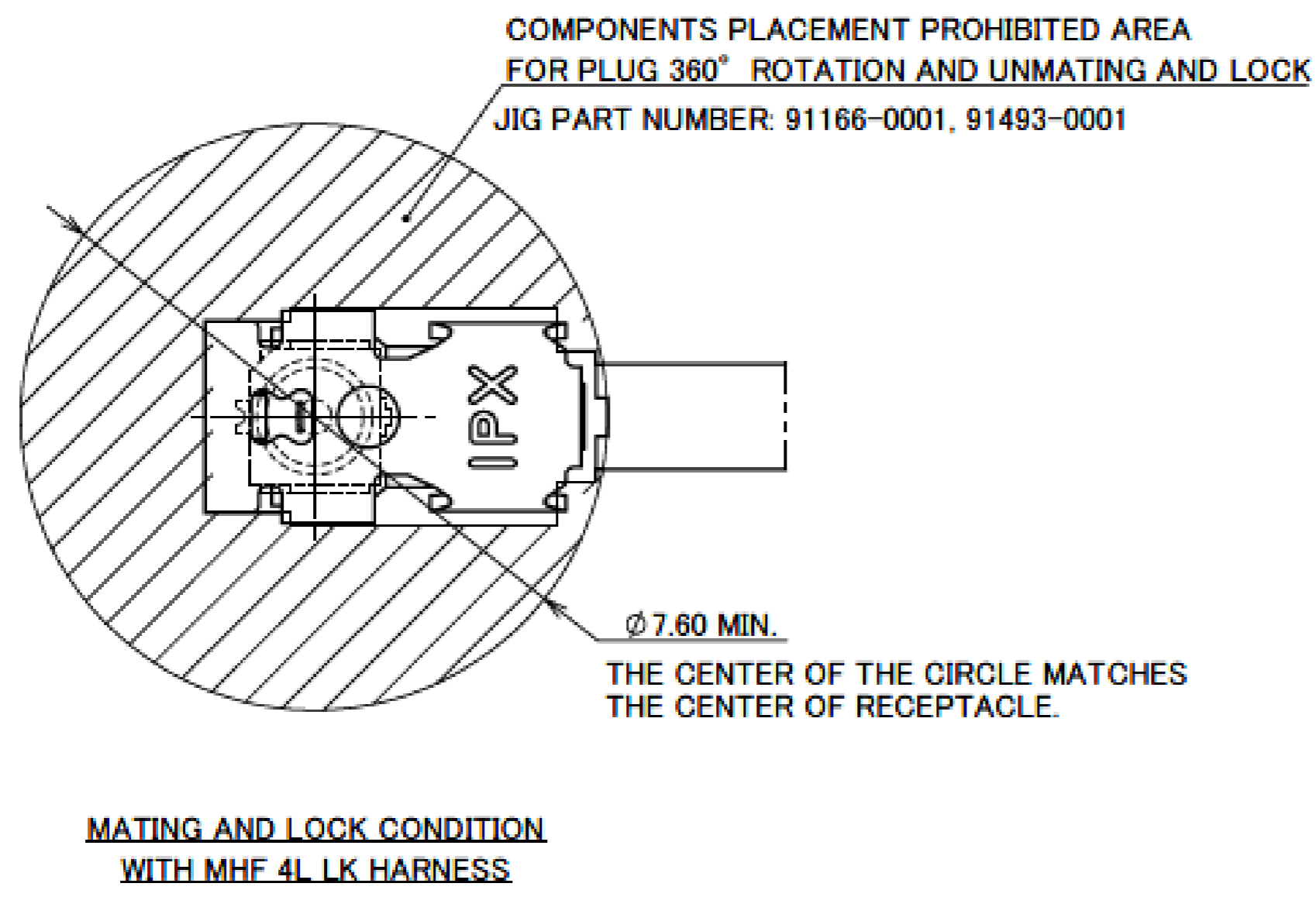

MULTIPLE CONNECTORS LAYOUT

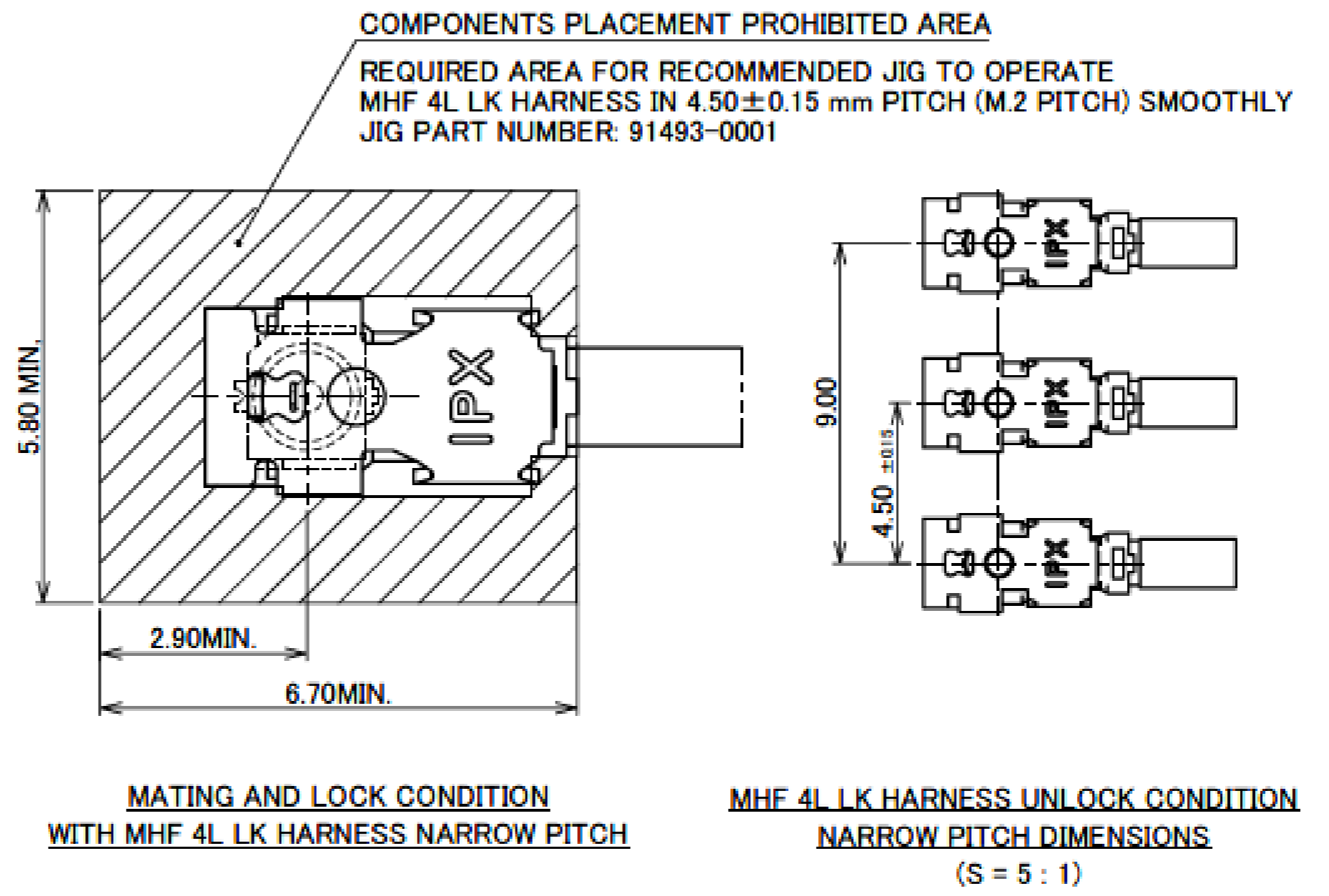

Rev.16

Accessories for MHF® 4 plug

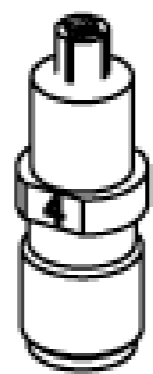

MHF 4 (4L) SMA ADAPTER
PART NO. 90449-002



MHF 4 RECEPTACLE HIGH CYCLE ATTACHMENT
PART NO. 90683-0001

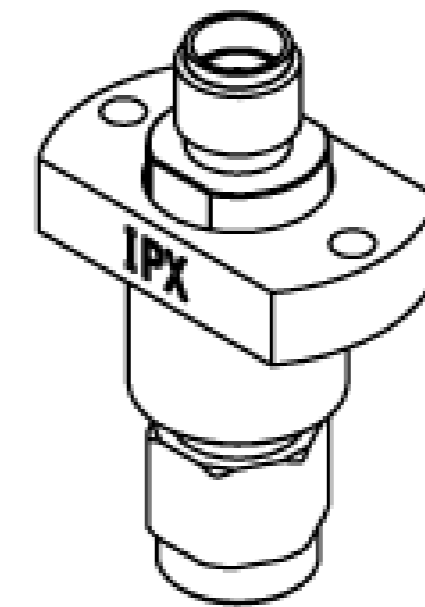

MHF SERIES HIGH CYCLE SMA ADAPTER BASE UNIT
PART NO. 90684-0001

* 90683-0001 AND 90684-0001 SHOULD BE USED TOGETHER.

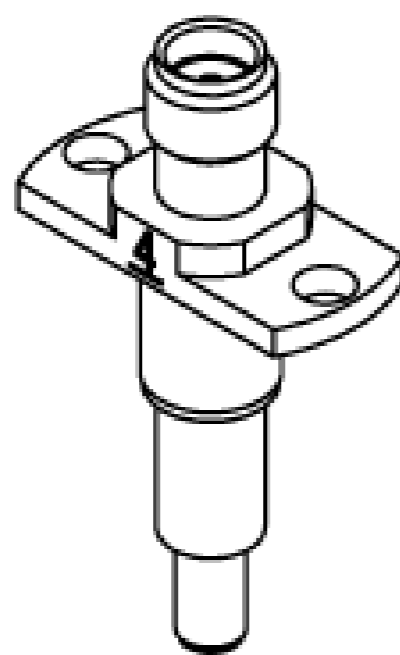

MHF 4 (4L) RECEPTACLE HIGH CYCLE SMA ADAPTER
PART NO. 90698-0001

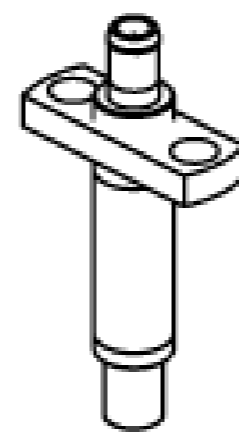

MHF 4 (4L) RECEPTACLE HIGH CYCLE N45 C ADAPTER
PART NO. 90576-0001

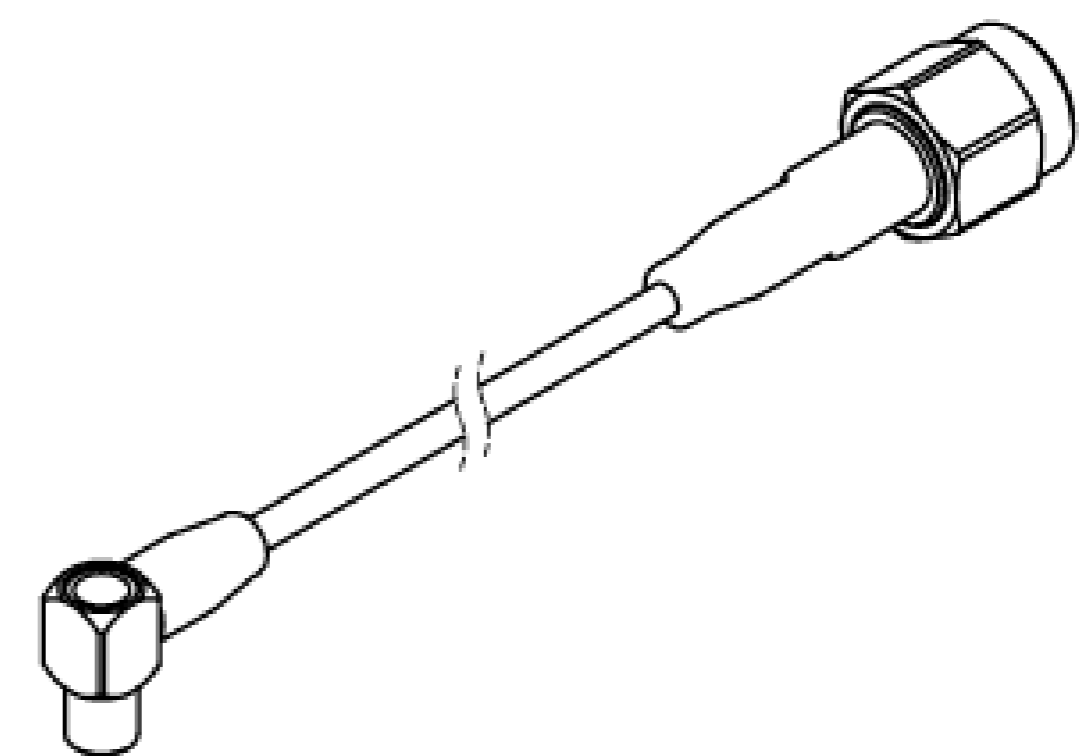

MHF SERIES N45 C TO SMA ADAPTER CABLE
PART NO. 90577-****

* 90576-0001 AND 90577-**** SHOULD BE USED TOGETHER.

Rev.16

Custom Connectors Available

RF Connectors

MHF® series

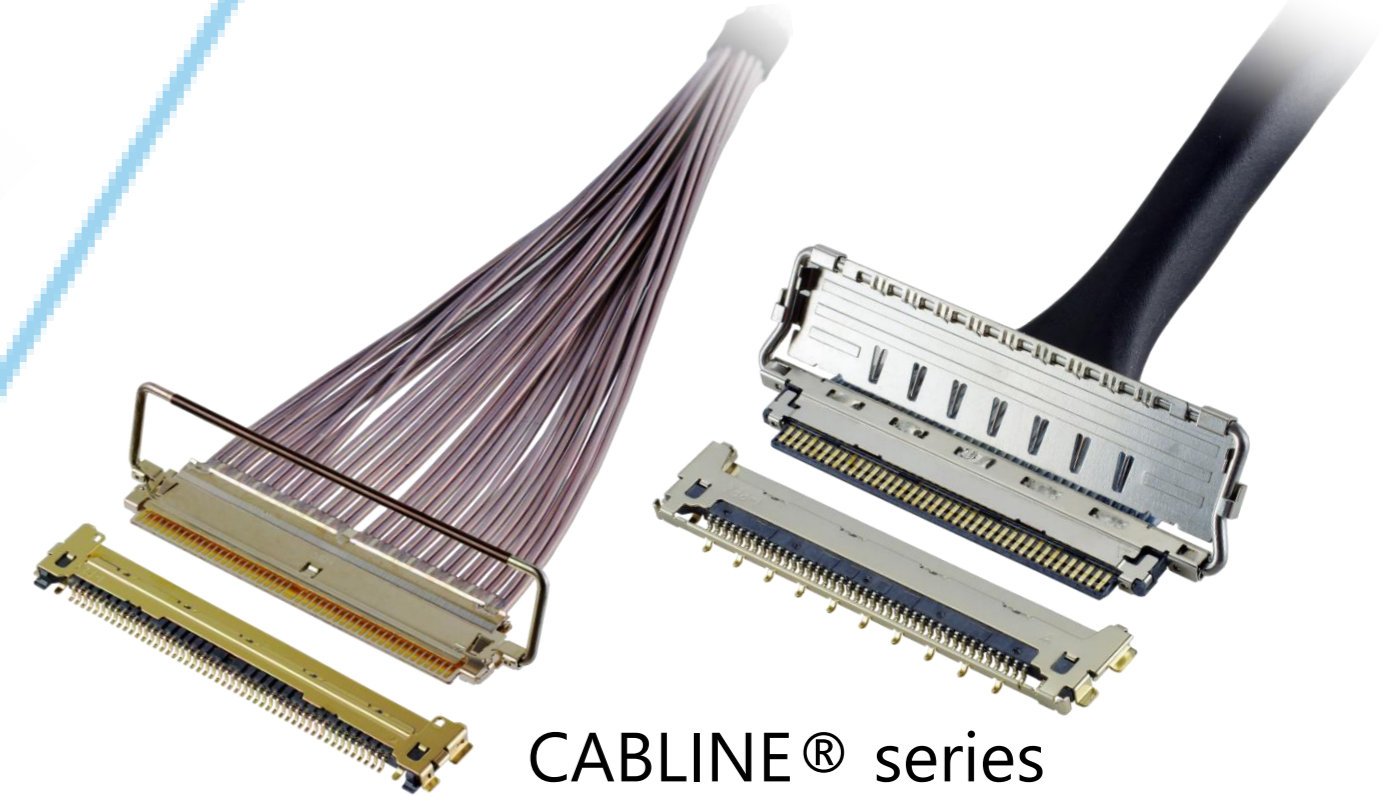

CABLINA® series

Micro-Coaxial/Twinaxial Connectors



Wire-to-Board Connectors/Terminals

AP series



ISH® series

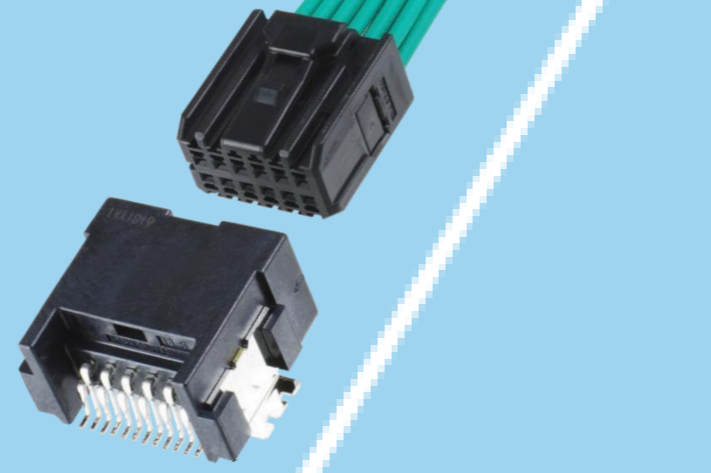

NOVASTACK® series



Board-to-Board Connectors



I/O Connectors

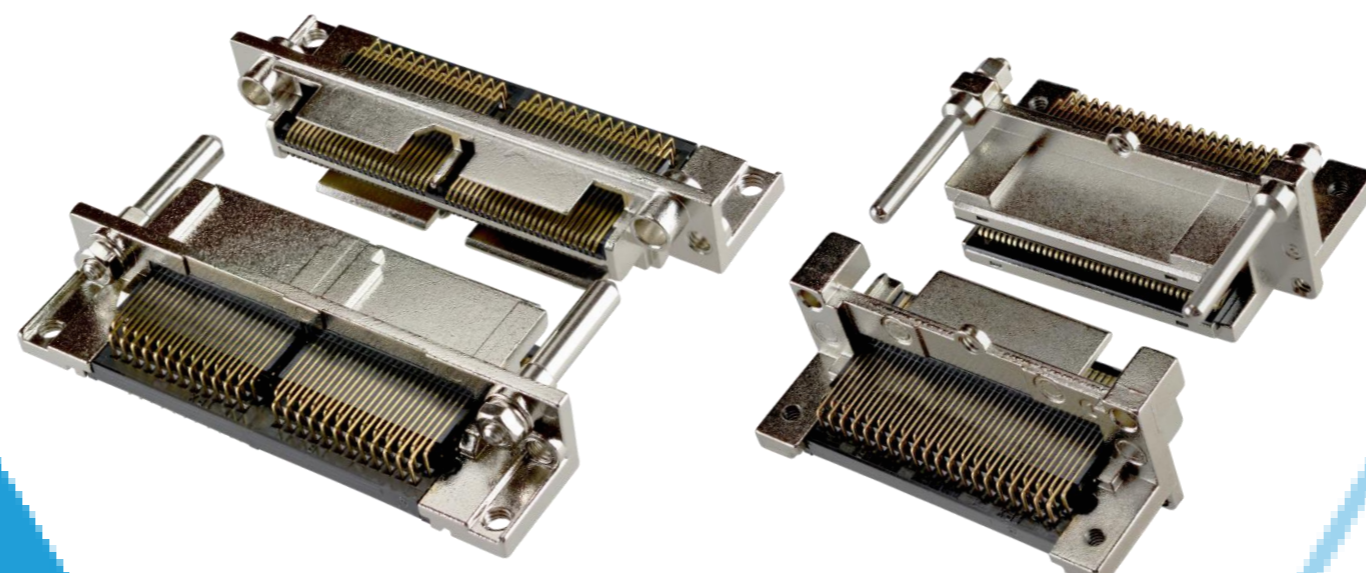

MINIDOCK™ series

MINIFLEX® series EVAFLEX® series

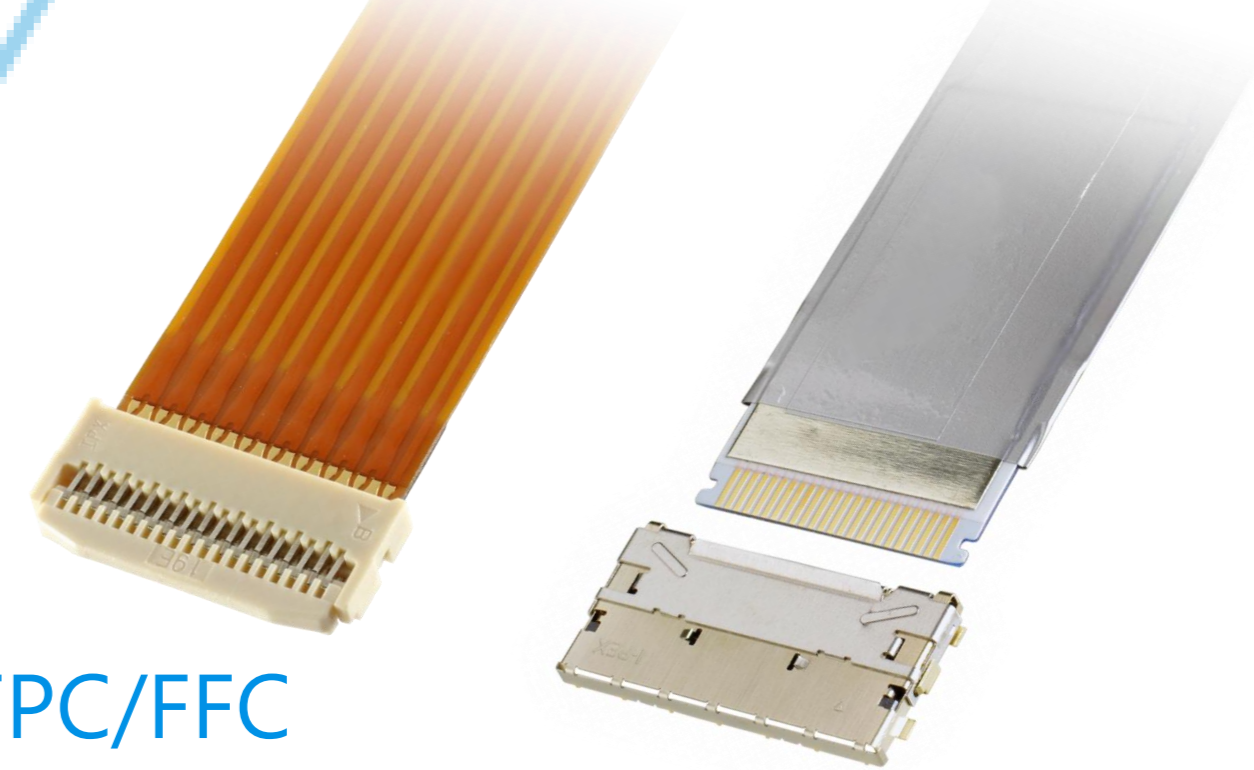

FPC/FFC Connectors



Inquiry



I-PEX, MHF, CABLINE, NOVASTACK, ISH, IARPB, MINIFLEX, EVAFLEX, MINIDOCK, i-Fit and ZenShield are registered trademarks of I-PEX Inc. Please note that the contents in the catalog might be changed without prior notification. I-PEX Inc. assumes no responsibility for any inaccuracies or obligation to update information on these documents. Please be sure to read and understand the latest "Precautions for Use" and "Instruction Manual" before you use our products. We shall not be responsible for any defects, damages or troubles in case you use our products without following the precautions for use. Please feel free to contact our sales representatives when you use our products for any applications that require very high reliability and safety, or that relate to human life (ex. nuclear power control, aerospace, transportation, medical equipment, safety equipment etc.).

Contact your sales representative or more detailed information.

www.i-pex.com

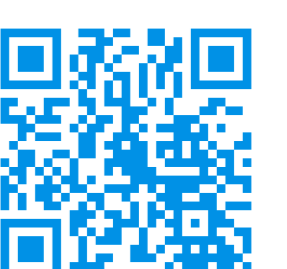

I-PEX

© I-PEX Inc. 2026
All rights reserved